



samson



THE STRONGEST NAME IN ROPE



**SAMSON BRINGS PRODUCTS
TO THE COMMERCIAL MARINE
MARKET THAT SAVE TIME AND
OPERATIONAL COSTS, WHILE
INCREASING LEVELS OF HANDLING
CREW SAFETY AND EFFICIENCY.**





SAMSON:

THE LINK BETWEEN TECHNOLOGY AND PRACTICAL APPLICATION.

SAMSON'S ENGINEERED SYNTHETIC ROPE PRODUCTS ARE STRONGER, LIGHTER, LAST LONGER, ARE EASIER AND SAFER TO HANDLE, AND SIGNIFICANTLY REDUCE OPERATING COSTS.

It's been proven in actual operating tests over several years with major commercial marine operators. As a replacement for wire rope in Mooring applications the savings are real and significant in both time and costs. For Tug Assist operations, smaller crews are required for rope handling, and the new synthetics from Samson outlast competing products by a considerable margin. The results are reduced cost of operations and reduced operating times in both moorings and ship assists, as well as a safer, more efficient workplace with reduced potential for environmental damage.



SAMSON:

A TRADITION OF STRENGTH, A LEGACY OF INNOVATION.

These products are the result of Samson's commitment to technological leadership in rope design and manufacturing. It is not a new idea; for over 125 years Samson has been developing innovative products bringing the best of current fiber technology to the workplace. Samson partners with our customers to provide engineered solutions to real-world problems, and follows up with assistance at installations, full documentation, and training on rope inspection and retirement criteria. We're committed to making certain all our products perform as designed – no matter what the application.

Samson has made a significant investment in research and development and quality assurance. We maintain one of the largest test facilities in the industry, with tensile testing capacity that is unmatched. Every product is fully documented to comply with all specifications.

Throughout the years, Samson Rope Technologies has remained at the forefront of fiber technology. Working closely with the world's leading fiber suppliers, Samson engineers are among the first to incorporate the latest developments in fiber technology to provide unique solutions to industry challenges. As the interface between fiber development and practical application, Samson brings products to the commercial marine market that save time and operational costs, increase crew rope handling safety, and reduce the need for environmentally damaging maintenance routines.

BRING THE STRENGTH OF SAMSON TO YOUR COMMERCIAL MARINE OPERATION.

Let Samson be part of the solution to your operational problems. Talk to an application engineer or trained sales representative who can recommend a product for your application, or help develop a solution engineered and produced specifically to address the requirements of your operation. The strength of Samson will help make your marine operations safer and more efficient while reducing operating costs.



samson

1-800-227-7673
www.samsonrope.com

From research and development... Through testing and documentation... To the manufacturing floor...

**SAMSON HAS DEDICATED
MORE RESOURCES THAN
ANY OTHER CORDAGE
MANUFACTURER TO THE
CONTINUED DEVELOPMENT
OF HIGH PERFORMANCE
SYNTHETIC ROPE PRODUCTS.**

A LEGACY OF INNOVATION BUILT ON A COMMITMENT TO TECHNOLOGY.

RESEARCH & DEVELOPMENT

We maintain one of the largest research and development organizations in the industry – fully equipped with the latest laboratory facilities, abrasion testing equipment, and one of the highest capacity tensile testers (1.1 million pounds) of any manufacturer worldwide. Staffed by fiber technologists and engineers dedicated to the development of more efficient and stronger ropes, Samson continues to lead the industry in technological developments in fibers, coatings and constructions. The staff works directly with the leading fiber manufacturers to explore and assess the properties of new fibers in development.



Dyneema®

A close relationship with DSM High Performance Fibers BV, makers of Dyneema, insures Samson will remain on the forefront of new fiber technology.

This partnership with our fiber suppliers is a key to innovation, research and development.

The engineering staff also works closely with field sales personnel as application engineers. This interactive relationship allows us to be responsive to the operational concerns of our customers. From on-site assistance with installation of new products, to evaluation of product performance and the development of safety standards, the application engineer is an integral part of the field sales team.



Samson's Vice President of Research & Development frequently visits Samson customers to inspect and evaluate product performance and research new product development.



Samson ropes are designed and built to meet real world challenges.

All new product development as well as production of existing product is subject to stringent inspection, testing and documentation. Our plants are equipped with certified test equipment to assess the characteristics of all raw materials as well as finished goods.

Testing capabilities include:

- Certified elongation and break testing of rope up to 1.1 million pounds sample lengths of up to 50 feet.
- Wet and dry accelerated and reverse bend abrasion testing
- Rope analysis for construction and fiber type
- Extraction testing for lubricant content of rope
- Termination evaluation and development

SAMSON WAS ONE OF THE FIRST U.S. ROPE MANUFACTURERS TO RECEIVE ISO 9001 CERTIFICATION, A NATURAL PROGRESSION OF OUR EXISTING QUALITY ASSURANCE PROGRAM THAT INCORPORATES:

- Integrated product development and production software that translates engineering specifications into production orders for manufacturing
- Specialized production documents for processing high modulus fibers
- Standardized procedures for inspection, analysis, and testing of in-process product as well as finished goods
- Individual specifications for all products



Based on our Quality Assurance Program, Samson has received product type approval certifications from: **ABS** – American Bureau of Shipping
NK – Nippon Kaiji Kyokai
DNV – Det Norske Veritas



Product certifications are available upon request with order placement. As a long standing active member of the Cordage Institute, Samson has been a major contributor in developing standards and specifications on behalf of the Cordage Institute.

ABOUT THIS CATALOG:

CLASSIFICATION OF ROPE PRODUCTS BY CLASS I & CLASS II

We have divided our product offering into two classes of ropes. Class II Ropes are produced from high performance synthetic fibers that are designed as potential replacements for wire rope applications. Class I Ropes are constructed of traditional synthetic fibers that are not designed as alternative products for wire rope replacement.

A detailed description of Class II and Class I Ropes, is located in the Glossary of Terms on pages 49-50. The designation of Class II and Class I Ropes to a specific product should also be used in selecting the appropriate Samson splice and testing procedure for that product.

TABLE OF CONTENTS:

- **HIGH PERFORMANCE ROPES (CLASS II)**
 - AmSteel-Blue [code 872] 6
 - Force-8 [code 871] 7
 - Neutron-8 [code 867] 8
 - Proton 8 [code 830] 9
 - DPX-75 [code 865] 10
 - TSII Premium [code 880] 11
 - Validator I2 [code 446] 12
 - Tech-I2 [code 890] 12
- **COMPARATIVE DATA**
 - Primary Mooring Lines 13
 - Pendants for Primary Mooring Lines 14
 - Secondary Mooring Lines 15
 - Tug Assist/Maneuvering Lines 16
 - Pendants for Tug Assist/Maneuvering Lines 17
- **SAMSON ENGINEERED SOLUTIONS**
 - Testimonials and Product Solutions 18-21
- **STANDARD PERFORMANCE ROPES (CLASS I)**
 - Round Plait: SSR-I200 [code 416] 22
 - Round Plait: Polyester [code 402] 23
 - Round Plait: Ultra Blue [code 333] 24
 - Round Plait: PNX [code 415] 25
 - Double Braid: 2-In-1 Stable Braid [code 506] 26
 - Double Braid: 2-In-1 Super Strong Nylon [code 472] ... 27
 - 8-Strand: SSR-I200 [code 263] 28
 - 3-Strand: SSR-I200 [code 220] 29
 - 8-Strand: Ultra Blue [code 252] 30
 - 3-Strand: Ultra Blue [code 130] 30
 - 8-Strand: Pro-Set Nylon [code 256] 31
 - 3-Strand: Pro-Set Nylon [code 170] 31
 - 3-Strand: SSR-301R [code 226] 32
- **ACCESSORIES**
 - Splicing Tools & Instructions 33
 - Thimbles 34
 - Chafe Protection 35
- **TECHNICAL SUPPORT INFORMATION**
 - Samthane Coatings 36
 - Fiber Characteristics & Rope Constructions 37
 - Elongation Components & Definitions 38
 - Rope Handling 39
 - Winch, Bending Radius & Pin Diameter Info 40-41
 - Standards for Strength & Determination 42-43
 - Rope Inspection & Retirement Guidelines 44-48
 - Glossary of Terms 49-50
 - Standards Conversion Chart 50
 - Spotlight Gallery 51



AMSTEEL-BLUE: THE BEST ALL-AROUND DYNEEMA ROPE, A DIRECT REPLACEMENT FOR WIRE ROPES PROVEN TO REDUCE TUG ASSIST AND MOORING COSTS.

FEATURES:

- Uses Dyneema® SK-75 HMPE fiber
- A size for size strength replacement for wire rope at only 1/7th the weight
- Torque-free, very flexible, easy to handle
- Similar elastic elongation to wire rope
- Easily inspected or field spliced
- Floats

APPLICATIONS:

- Primary vessel mooring lines
- Tractor tug working lines off winch drum
- Face and wing wires for push tugs
- Emergency and seismic tow lines

AMSTEEL-BLUE IS A PROVEN COST-SAVING REPLACEMENT FOR WIRE ROPE IN KEY APPLICATIONS WHERE STRENGTH, WEIGHT AND SAFETY ARE IMPORTANT.

Recognized worldwide as the standard for single braid HMPE ropes, AmSteel-Blue® is easily spliced and inspected. These features, with the superior wear and flex fatigue of Dyneema SK-75 fiber and Samthane™ coating, are combined in a torque-free 12-strand single braid design. The result is an industry leading braided synthetic rope that outlasts wire rope and has proven operator cost saving benefits.

AmSteel-Blue, at only 1/7th the weight of wire, requires less committed crew for mooring operations, significantly reduces mooring times and tug costs, and improves crew safety. The reduced weight, high strength and low stretch also make it ideal for Tug Assist/maneuvering lines, resulting in quick, efficient connections and control response. AmSteel-Blue is proven to provide longer service life and reduced costs in a variety of applications.

Standardized working pendants are available for mooring and tug assist lines, see page (14 & 17).

Recommended for split drum winch applications; not recommended for use on H-bitts, capstans or cleats if surging or rendering the rope is required.



12-STRAND

AMSTEEL-BLUE®

Size Dia. Inches	Size Circ. Inches	Weight lbs. Per 100 FT.	SRT MBS/lbs.	Size Dia. mm	Weight KG Per 100 M	SRT MBS/Metric Tonnes	ISO/BS EN919 Strength/Metric Tonnes
3/16"	9/16"	1.0 lbs.	4,900 lbs.	5mm	1.5 Kg	2.2 MT	2.5 MT
1/4"	3/4"	1.6 lbs.	7,700 lbs.	6mm	2.4 Kg	3.5 MT	3.9 MT
5/16"	1"	2.7 lbs.	12,300 lbs.	8mm	4.0 Kg	5.6 MT	6.2 MT
3/8"	1-1/8"	3.6 lbs.	17,600 lbs.	9mm	5.4 Kg	8.0 MT	8.9 MT
7/16"	1-1/4"	4.2 lbs.	21,500 lbs.	11mm	6.3 Kg	9.8 MT	10.8 MT
1/2"	1-1/2"	6.4 lbs.	30,600 lbs.	12mm	9.5 Kg	13.9 MT	15.4 MT
9/16"	1-3/4"	7.9 lbs.	36,500 lbs.	14mm	11.8 Kg	16.6 MT	18.4 MT
5/8"	2"	10.2 lbs.	47,500 lbs.	16mm	15.2 Kg	21.5 MT	23.9 MT
3/4"	2-1/4"	13.3 lbs.	58,000 lbs.	18mm	19.8 Kg	26.3 MT	29.2 MT
7/8"	2-3/4"	19.6 lbs.	81,700 lbs.	22mm	29.2 Kg	37.1 MT	41.2 MT
1"	3"	21.8 lbs.	98,100 lbs.	24mm	32.4 Kg	44.5 MT	49.4 MT
1-1/16"	3-1/4"	27.5 lbs.	118,000 lbs.	26mm	40.9 Kg	53.5 MT	59.5 MT
1-1/8"	3-1/2"	31.9 lbs.	133,000 lbs.	28mm	47.5 Kg	60.3 MT	67.0 MT
1-1/4"	3-3/4"	36.2 lbs.	149,000 lbs.	30mm	53.9 Kg	67.6 MT	75.1 MT
1-5/16"	4"	41.8 lbs.	166,000 lbs.	32mm	62.2 Kg	75.3 MT	83.7 MT
1 3/8"	4-1/8"	45.0 lbs.	185,000 lbs.	34mm	67.0 Kg	83.9 MT	93.2 MT
1-1/2"	4-1/2"	51.7 lbs.	205,000 lbs.	36mm	76.9 Kg	93.0 MT	103.3 MT
1-5/8"	5"	65.2 lbs.	255,000 lbs.	40mm	97.0 Kg	115.7 MT	128.5 MT
1-3/4"	5-1/2"	78.4 lbs.	302,000 lbs.	44mm	116.7 Kg	137.0 MT	152.2 MT
2"	6"	87.0 lbs.	343,000 lbs.	48mm	129.5 Kg	155.6 MT	172.9 MT
2-1/8"	6-1/2"	109.0 lbs.	411,000 lbs.	52mm	162.2 Kg	186.4 MT	207.1 MT
2-1/4"	7"	116.0 lbs.	484,000 lbs.	56mm	172.6 Kg	219.5 MT	243.9 MT
2-1/2"	7-1/2"	148.0 lbs.	529,000 lbs.	60mm	220.3 Kg	240.0 MT	266.6 MT
2-5/8"	8"	167.0 lbs.	595,000 lbs.	64mm	248.5 Kg	269.9 MT	299.9 MT
2-3/4"	8-1/2"	187.0 lbs.	662,000 lbs.	68mm	278.3 Kg	300.3 MT	333.6 MT
3"	9"	206.0 lbs.	748,000 lbs.	72mm	306.6 Kg	339.3 MT	377.0 MT
3-1/4"	10"	240.0 lbs.	906,000 lbs.	80mm	357.2 Kg	411.0 MT	456.6 MT

AMSTEEL-BLUE

PRODUCT CODE: 872

TECHNICAL SPECIFICATIONS:

CLASS II ROPE

SPECIFIC GRAVITY:
.98 (floats)

ELASTIC ELONGATION PERCENTAGE:
At % of break strength
10% 0.46%
20% 0.70%
30% 0.96%

SPLICING PROCEDURES REQUIRED:

- EYE SPLICE – 12-Strand/Class II Rope
- END FOR END SPLICE – 12-Strand/Class II Rope

SAMSON



8x3-STRAND™

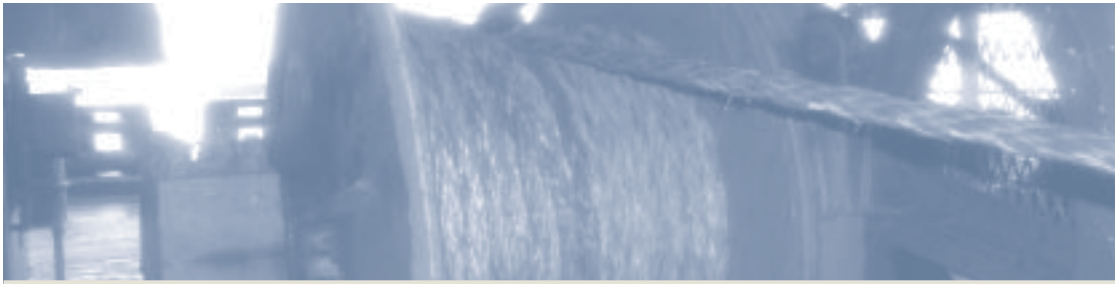

FORCE-8: A UNIQUE, PATENTED CONSTRUCTION DYNEEMA MOORING LINE WITH A FIRM CROSS SECTION SPECIALLY DESIGNED FOR SINGLE/SPLIT DRUM WINCH APPLICATIONS.

FEATURES:

- 8x3 Torque-free braided construction minimizes drum compression
- A floating, flexible Dyneema SK-75 HMPE fiber rope
- Lightweight handling for crews with increased safety
- Ease of splicing and excellent UV resistance

APPLICATIONS:

- Primary vessel mooring line
- Face and wing wires for push tugs
- First line ashore salvage line
- Small vessel emergency tow line
- Deep water lifting line

The unique, patented construction has a firm cross-section designed for single drum and split drum winch applications. The firm construction results in reduced compression and minimizes diving on the drum, while still providing the high strength, low weight, and excellent flex fatigue resistance of a Dyneema rope.

The Samthane coating applied to the rope gives added wear protection without impacting flexibility or ease of splicing. Force-8 is available in long continuous production block creel lengths to meet the needs of deep water mooring or lifting projects. The design of Force-8 allows for easy visual inspection and verification of internal and external strand wear.

Recommended for split drum or single drum winch applications; not recommended for use on H-bitts, capstans or cleats if surging or rendering the rope is required.

FORCE-8

PRODUCT CODE: 871

TECHNICAL SPECIFICATIONS:

CLASS II ROPE

SPECIFIC GRAVITY:
.98 (floats)

ELASTIC ELONGATION PERCENTAGE:

- At % of break strength
- 10% 0.70%
- 20% 0.90%
- 30% 1.20%

SPLICING PROCEDURES REQUIRED:

- EYE SPLICE – 8x3-Strand/Class II Rope
- END FOR END SPLICE – 8x3-Strand/Class II Rope

Size Dia. Inches	Size Circ. Inches	Weight lbs. Per 100 FT.	SRT MBS/lbs.	Size Dia. mm	Weight KG Per 100 M	SRT MBS/Metric Tonnes	ISO/BS EN919 Strength/Metric Tonnes
1"	3"	21.6 lbs.	85,000 lbs.	24mm	32.1 Kg	38.6 MT	42.8 MT
1-1/16"	3-1/4"	25.3 lbs.	98,000 lbs.	26mm	37.7 Kg	44.5 MT	49.4 MT
1-1/8"	3-1/2"	29.2 lbs.	112,000 lbs.	28mm	43.5 Kg	50.8 MT	56.4 MT
1-1/4"	3-3/4"	33.4 lbs.	127,000 lbs.	30mm	49.7 Kg	57.6 MT	64.0 MT
1-5/16"	4"	37.9 lbs.	143,000 lbs.	32mm	56.4 Kg	64.9 MT	72.1 MT
1-3/8"	4-1/8"	41.0 lbs.	152,000 lbs.	34mm	61.0 Kg	68.9 MT	76.6 MT
1-1/2"	4-1/2"	47.6 lbs.	176,000 lbs.	36mm	70.8 Kg	79.8 MT	88.7 MT
1-5/8"	5"	58.5 lbs.	213,000 lbs.	40mm	87.1 Kg	96.6 MT	107.4 MT
1-3/4"	5-1/2"	70.4 lbs.	253,000 lbs.	44mm	104.8 Kg	114.8 MT	127.5 MT
2"	6"	83.4 lbs.	296,000 lbs.	48mm	124.1 Kg	134.3 MT	149.2 MT

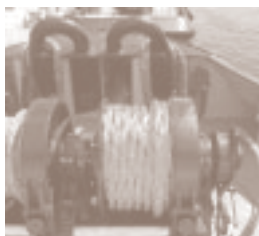

PRODUCT SPOTLIGHT

Samson uses Dyneema SK-75 HMPE (High Modulus PolyEthylene) fiber for high performance ropes to maximize strength and minimize weight. Dyneema SK-75 represents the most technically advanced "virgin" HMPE fiber available for rope manufacturing. Since it is not a "post-drawn" or "heat-set" HMPE fiber, SK-75 translates into Samson ropes with the highest flex-fatigue resistance and longest service life; superior to other synthetics such as nylon, olefins, polyester or aramids.

FORCE-8™



NEUTRON-8: THE STRONGEST ROPE MADE BY SAMSON. PATENTED 8x3-STRAND™ DYNEEMA CONSTRUCTION WITH A FIRM CROSS SECTION FOR USE ON WINCHES.

FEATURES:

- Firm shape retention on single drum winch applications
- Available in large diameter sizes and long lengths without internal braider splices
- Low stretch, high durability and easy to splice
- A flexible Dyneema SK-75 HMPE fiber rope
- A floating wire rope replacement

APPLICATIONS:

- Tractor Tug single drum assist/ Maneuvering Lines
- Specialized deep water mooring or lifting projects
- First line ashore/emergency tow line
- Wire rope lifting sling replacement

Neutron-8™ is an excellent floating replacement for large diameter wire rope or chain. The unique, patented Dyneema construction results in the highest strength to weight ratio, with reduced compression and less diving on winch drums. Neutron-8's features make it ideal for tractor tug working lines and a variety of specialty deep water applications where long lengths, high strength and low weight are critical.

If high strength, flexibility and lightweight are the prime performance requirements for your application, Neutron-8 sets the standard.

Recommended for split drum or single drum winch applications; not recommended for use on H-bitts, capstans or cleats if surging or rendering the rope is required.



8x3-STRAND™

Size Dia. Inches	Size Circ. Inches	Weight lbs. Per 100 FT.	SRT MBS/lbs.	Size Dia. mm	Weight KG Per 100 M	SRT MBS/Metric Tonnes	ISO/BS EN919 Strength/Metric Tonnes
2"	6"	89.8 lbs.	405,000 lbs.	48mm	133.6 Kg	183.7 MT	204.1 MT
2-1/8"	6-1/2"	101.4 lbs.	441,000 lbs.	52mm	150.9 Kg	200.0 MT	222.3 MT
2-1/4"	7"	113.7 lbs.	490,000 lbs.	56mm	169.2 Kg	222.3 MT	247.0 MT
2-1/2"	7-1/2"	140.3 lbs.	596,000 lbs.	60mm	208.7 Kg	270.3 MT	300.4 MT
2-5/8"	8"	154.7 lbs.	652,000 lbs.	64mm	230.2 Kg	295.7 MT	328.6 MT
2-3/4"	8-1/2"	169.8 lbs.	711,000 lbs.	68mm	252.6 Kg	322.5 MT	358.3 MT
3"	9"	202.1 lbs.	835,000 lbs.	72mm	300.7 Kg	378.8 MT	420.8 MT
3-1/4"	10"	237.1 lbs.	998,000 lbs.	80mm	352.8 Kg	452.7 MT	503.0 MT
3-5/8"	11"	295.0 lbs.	1,185,000 lbs.	88mm	439.0 Kg	537.5 MT	597.2 MT
4"	12"	359.2 lbs.	1,422,000 lbs.	96mm	534.6 Kg	645.0 MT	716.7 MT
4-1/4"	13"	405.5 lbs.	1,591,000 lbs.	104mm	603.5 Kg	721.7 MT	801.9 MT
4-5/8"	14"	480.2 lbs.	1,861,000 lbs.	112mm	714.6 Kg	844.1 MT	937.9 MT
5"	15"	561.3 lbs.	2,150,000 lbs.	120mm	835.3 Kg	975.2 MT	1,083.6 MT
5-1/4"	16"	618.8 lbs.	2,353,000 lbs.	128mm	920.9 Kg	1,067.3 MT	1,185.9 MT
5-1/2"	17"	679.1 lbs.	2,565,000 lbs.	136mm	1010.6 Kg	1,163.5 MT	1,292.8 MT
6"	18"	808.2 lbs.	3,013,000 lbs.	144mm	1202.8 Kg	1,366.7 MT	1,518.6 MT

NEUTRON-8

PRODUCT CODE: 876

TECHNICAL SPECIFICATIONS:

CLASS II ROPE

SPECIFIC GRAVITY:

.98 (floats)

ELASTIC ELONGATION PERCENTAGE:

At % of break strength

10% 0.70%

20% 0.90%

30% 1.20%

SPLICING PROCEDURES REQUIRED:

- EYE SPLICE – 8x3-Strand/Class II Rope
- END FOR END SPLICE – 8x3-Strand/Class II Rope

NEUTRON-8™



PRODUCT SPOTLIGHT

Samson pioneered the implementation of HMPE tug assist lines with Amsteel-Blue. The extremely lightweight, low water absorbing braided Dyneema ropes have replaced wire rope or other larger circumference and heavier polyester working lines. Products such as Amsteel-Blue, Neutron-8, and Proton 8 allow tug operators to handle lines with fewer crew members, thus saving money.



8-STRAND



PROTON 8: THE GRIP NEEDED FOR H-BITT OPERATIONS, WITH THE STRENGTH OF DYNEEMA IN A FIRM YET FLEXIBLE ROPE.

FEATURES:

- High grip and heat resistance
- High strength to weight ratio with low water absorption for lightweight handling
- Flexible, torque-free 8-strand with a firm cross-section
- Easy to field splice

APPLICATIONS:

- Tug Assist/Maneuvering Lines on H-bitts
- Primary or secondary vessel mooring lines
- Ship "tug" lines – stored on winch drum or faked on deck
- Barge tie-up lines

PROTON 8 IS AN EXCELLENT VERSATILE DYNEEMA HMPE ROPE WHICH PROVIDES COST SAVING BENEFITS IN A MULTITUDE OF MARINE APPLICATIONS.

Proton 8™ uses Dyneema SK-75 for high strength and low weight with a polyester overlay to provide the heat resistance and grip necessary for use on bitts and capstans. Its firm, flexible, torque-free construction performs well on both single and split drum winches.

Compared to all polyester or polyester/polypro combo ropes, Proton 8 is over twice as strong and weighs less size for size. It provides substantially better service life, is almost neutrally buoyant, and has low water absorption for ease and speed of handling during deployment and retrieval. The yellow Samthane coating insures maximum wear resistance and service life while making Proton 8 highly visible.

This unique Dyneema working line is a proven solution to the problem of large, heavy ropes that are difficult to manage, and add opportunity for crew injury.

Designed for use on H-bitts and capstans for surging and rendering.

PROTON 8

PRODUCT CODE: 830

TECHNICAL SPECIFICATIONS:

CLASS II ROPE

SPECIFIC GRAVITY:

1.09

ELASTIC ELONGATION PERCENTAGE:

At % of break strength

10% 0.58%

20% 0.87%

30% 0.96%

SPLICING PROCEDURES REQUIRED:

- EYE SPLICE – 8-Strand/Class II Rope
- END FOR END SPLICE – 8-Strand/Class II Rope

Size Dia. Inches	Size Circ. Inches	Weight lbs. Per 100 FT.	SRT MBS/lbs.	Size Dia. mm	Weight KG Per 100 M	SRT MBS/Metric Tonnes	ISO/BS EN919 Strength/Metric Tonnes
1"	3"	25.0 lbs.	55,000 lbs.	24mm	37.2 Kg	24.9 MT	27.7 MT
1-1/8"	3-1/2"	30.5 lbs.	69,000 lbs.	28mm	45.4 Kg	31.3 MT	34.8 MT
1-1/4"	3-3/4"	38.5 lbs.	87,000 lbs.	30mm	57.3 Kg	39.5 MT	43.8 MT
1-5/16"	4"	41.5 lbs.	104,000 lbs.	32mm	61.8 Kg	47.2 MT	52.4 MT
1-3/8"	4-1/8"	46.0 lbs.	108,000 lbs.	34mm	68.5 Kg	49.0 MT	54.4 MT
1-1/2"	4-1/2"	55.4 lbs.	125,000 lbs.	36mm	82.4 Kg	56.7 MT	63.0 MT
1-5/8"	5"	68.0 lbs.	140,000 lbs.	40mm	101.2 Kg	63.5 MT	70.6 MT
1-3/4"	5-1/2"	74.8 lbs.	190,000 lbs.	44mm	111.3 Kg	86.2 MT	95.8 MT
2"	6"	99.0 lbs.	237,000 lbs.	48mm	147.3 Kg	107.5 MT	119.4 MT
2-1/8"	6-1/2"	112.3 lbs.	277,000 lbs.	52mm	167.1 Kg	125.6 MT	139.6 MT
2-1/4"	7"	125.3 lbs.	316,000 lbs.	56mm	186.5 Kg	143.3 MT	159.3 MT
2-3/8"	7-1/8"	139.7 lbs.	383,000 lbs.	57mm	207.9 Kg	173.7 MT	193.0 MT
2-1/2"	7-1/2"	149.3 lbs.	396,000 lbs.	60mm	222.2 Kg	179.6 MT	199.6 MT
2-5/8"	8"	172.4 lbs.	435,000 lbs.	64mm	256.6 Kg	197.3 MT	219.2 MT
2-3/4"	8-1/2"	188.0 lbs.	468,000 lbs.	68mm	279.8 Kg	212.3 MT	235.9 MT
3"	9"	197.8 lbs.	542,000 lbs.	72mm	294.4 Kg	245.9 MT	273.2 MT
3-1/4"	10"	253.9 lbs.	628,000 lbs.	80mm	377.9 Kg	284.9 MT	316.5 MT

PROTON 8™



DPX-75: THE BEST JACKETED DYNEEMA MOORING LINE AVAILABLE, WITH OVER TWICE THE SERVICE LIFE OF WIRE ROPES.

FEATURES:

- DPX fiber jacket provides excellent grip on winch drums and heat resistance
- One-sixth the weight of wire rope and it floats
- Firm round cross-section for superior winch performance
- Lightweight handling performance reduces mooring related injuries

APPLICATIONS:

- Primary mooring lines for single or split drum winches
- Winch line for deep water lifting projects

DPX-75 WAS CREATED THROUGH AMSTEEL-BLUE 12-STRAND CORE TECHNOLOGY COMBINED WITH A PROPRIETARY BRAIDED JACKET DESIGN OF DYNEEMA AND POLYESTER FIBERS.

A unique bonding material combines the cover and 12-strand core of Dyneema SK-75 to insure no movement between the two components. This construction creates a very firm round rope that will have minimal flattening under load and little tendency to dive or jam on winch drums.

DPX-75™ was designed to replace wire rope on winch drums but not to serve as a marine working rope. This firm construction works extremely well as a mooring or winch line.

When a jacketed mooring line is preferred, DPX-75 will give the maximum mooring line performance on the market.

A standard cover repair kit is available and easy to field apply. This product design requires specialized splicing techniques that does not facilitate field splicing.



CORE DEPENDANT

DPX-75™

Size Dia. Inches	Size Circ. Inches	Weight lbs. Per 100 FT.	SRT MBS/lbs.	Size Dia. mm	Weight KG Per 100 M	SRT MBS/Metric Tonnes	ISO/BS EN919 Strength/Metric Tonnes
1-1/8"	3-1/2"	33.0 lbs.	106,000 lbs.	28mm	49.1 Kg	48.1 MT	53.4 MT
1-1/4"	3-3/4"	36.0 lbs.	128,000 lbs.	30mm	53.5 Kg	58.1 MT	64.5 MT
1-5/16"	4"	42.0 lbs.	149,000 lbs.	32mm	62.5 Kg	67.6 MT	75.1 MT
1-3/8"	4-1/8"	45.0 lbs.	167,000 lbs.	34mm	66.9 Kg	75.8 MT	84.2 MT
1-1/2"	4-1/2"	51.5 lbs.	179,000 lbs.	36mm	76.6 Kg	81.2 MT	90.2 MT
1-5/8"	5"	58.0 lbs.	213,000 lbs.	40mm	86.3 Kg	96.6 MT	107.4 MT
1-11/16"	5-1/16"	65.0 lbs.	238,000 lbs.	42mm	96.7 Kg	108.0 MT	120.0 MT
1-3/4"	5-1/2"	69.5 lbs.	259,000 lbs.	44mm	103.4 Kg	117.5 MT	130.5 MT
2"	6"	84.5 lbs.	310,000 lbs.	48mm	125.7 Kg	140.6 MT	156.2 MT



PRODUCT SPOTLIGHT

Samson engineering has significantly increased the COF (coefficient of friction) of Dyneema HMPE fiber through the creation of DPX fiber. DPX is a unique blend of Dyneema (high strength, lightweight, high cut and abrasion resistance) and polyester (high heat resistance and COF) DPX provides a "prefuzzed" fiber appearance which wears well and grips winch drums. DPX – another Samson innovation.

DPX-75

PRODUCT CODE: 865

TECHNICAL SPECIFICATIONS:

CLASS II ROPE

SPECIFIC GRAVITY:
1.00

ELASTIC ELONGATION PERCENTAGE:
At % of break strength
10% 0.33%
20% 0.49%
30% 0.76%

SPLICING PROCEDURES REQUIRED:

- EYE SPLICE – Product specific
See instructions for DPX-75



CORE DEPENDANT

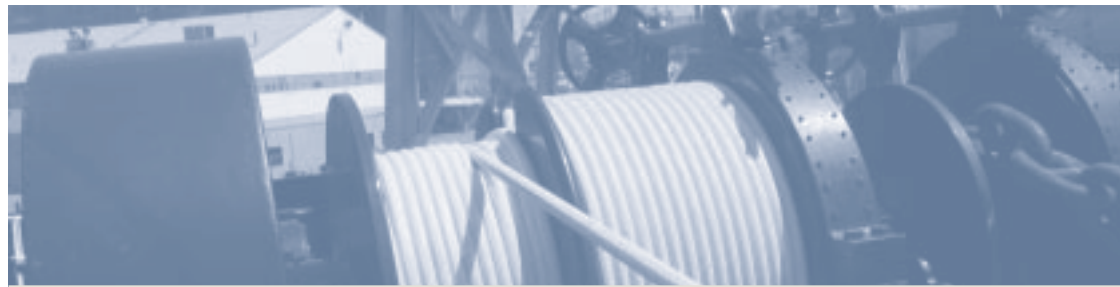

TSII PREMIUM: A SUPERIOR WIRE ROPE REPLACEMENT FOR WINCH DRUMS IN TRAWL SYSTEMS, WITH THE FIRMNESS AND LOW STRETCH OF WIRE BUT ONLY ONE SIXTH THE WEIGHT.

FEATURES:

- Excellent single drum spooling capabilities
- Superior drum compression resistance
- Retains hard round shape during use and has good flexibility
- Braided Dyneema fiber protective cover

APPLICATIONS:

- Single drum winch primary mooring lines for ATBs or other vessels
- Wire rope replacements in commercial fishing trawl systems
- Deep water lifting projects

PROVEN EFFECTIVE AS A GILSON WIRE ROPE REPLACEMENT IN THE TOUGHEST TRAWL COMMERCIAL FISHING APPLICATIONS.

TSII Premium™ has the relative firmness and low stretch of wire, yet only 1/6th the weight. Proven effective as a replacement for Gilson wire rope in the toughest conditions, TSII Premium is designed for reliable strength, long service life and light weight handling. Crew required for deployment and retrieval are minimized. Crew injuries associated with handling wire rope are eliminated, and tie-up and deployment times are reduced by half due to the light weight and improved handling characteristics.

The unique design of this floating line combines an internal braided control core that creates a very firm cross section for excellent spooling qualities, with an outer cover to protect the strength member from external wear and cutting. Both the cover and the core are braided from Samthane coated Dyneema. TSII Premium's highly abrasion/cut resistant non-strength cover insures a service life between 2 and 3 times that of wire mooring lines. The product is fully field spliceable and does not require the costly periodic re-lubrication process associated with wire rope.

TSII PREMIUM

PRODUCT CODE: 880

TECHNICAL SPECIFICATIONS:

CLASS II ROPE

SPECIFIC GRAVITY:
1.00

ELASTIC ELONGATION PERCENTAGE:

- At % of break strength
- 10% 0.70%
- 20% 0.90%
- 30% 1.20%

SPLICING PROCEDURES REQUIRED:

- EYE SPLICE – Product specific
- See instructions for TSII

Size Dia. Inches	Size Circ. Inches	Weight lbs. Per 100 FT.	SRT MBS/lbs.	Size Dia. mm	Weight KG Per 100 M	SRT MBS/Metric Tonnes	ISO/BS EN919 Strength/Metric Tonnes
1/2"	1-1/2"	8.1 lbs.	18,900 lbs.	12mm	12.1 Kg	8.6 MT	9.5 MT
9/16"	1-3/4"	9.8 lbs.	20,700 lbs.	14mm	14.6 Kg	9.4 MT	10.4 MT
5/8"	2"	12.5 lbs.	35,100 lbs.	16mm	18.6 Kg	15.9 MT	17.7 MT
3/4"	2-1/4"	16.5 lbs.	41,400 lbs.	18mm	24.6 Kg	18.8 MT	20.9 MT
7/8"	2-3/4"	24.0 lbs.	57,600 lbs.	22mm	35.7 Kg	26.1 MT	29.0 MT
1"	3"	30.5 lbs.	67,500 lbs.	24mm	45.4 Kg	30.6 MT	34.0 MT
1-1/8"	3-1/2"	39.0 lbs.	81,900 lbs.	28mm	58.0 Kg	37.1 MT	41.3 MT
1-1/4"	3-3/4"	46.0 lbs.	89,100 lbs.	30mm	68.5 Kg	40.4 MT	44.9 MT
1-1/2"	4-1/2"	66.8 lbs.	124,000 lbs.	38mm	99.4 Kg	56.2 MT	62.5 MT
1-5/8"	5"	74.0 lbs.	144,000 lbs.	40mm	110.1 Kg	65.3 MT	72.6 MT

TSII PREMIUM™



12-STRAND

VALIDATOR I2: DESIGNED FOR DEEP WATER LIFTING PROJECTS AND TOWED OR SUB SURFACE TAUT ARRAY SYSTEMS THAT REQUIRE A NON-FLOATING ROPE.

FEATURES:

- Very high strength with low stretch
- Non rotational/free running flexible construction
- High wear and heat resistance
- Fast easy splicing

APPLICATIONS:

- Towed or taut array systems
- Deep water lowering and retrieval lines

Validator I2™ is an extremely high strength, low stretch, non rotational 12-strand braid of Samthane coated Vectran® fiber. It is designed to meet the needs of deep water lifting projects and towed or sub surface taut array systems that require a non-floating rope. Based on its strength, size can be minimized to reduce drag and vortex strumming effects.

Size Dia. Inches	Size Circ. Inches	Weight lbs. Per 100 FT.	SRT MBS/lbs.	Size Dia. mm	Weight KG Per 100 M	SRT MBS/Metric Tonnes	ISO/BS EN919 Strength/Metric Tonnes
7/64"	5/16"	0.5 lbs.	1,800 lbs.	2.5mm	0.7 Kg	0.8 MT	0.9 MT
1/8"	3/8"	0.6 lbs.	2,400 lbs.	3mm	0.9 Kg	1.1 MT	1.2 MT
3/16"	9/16"	1.3 lbs.	5,000 lbs.	5mm	1.9 Kg	2.3 MT	2.5 MT
1/4"	3/4"	2.2 lbs.	8,500 lbs.	6mm	3.3 Kg	3.9 MT	4.3 MT
5/16"	1"	3.6 lbs.	12,600 lbs.	8mm	5.4 Kg	5.7 MT	6.4 MT
3/8"	1-1/8"	4.6 lbs.	17,600 lbs.	9mm	6.8 Kg	8.0 MT	8.9 MT
7/16"	1-1/4"	6.1 lbs.	21,200 lbs.	11mm	9.1 Kg	9.6 MT	10.7 MT
1/2"	1-1/2"	8.8 lbs.	31,500 lbs.	12mm	13.1 Kg	14.3 MT	15.9 MT
9/16"	1-3/4"	10.8 lbs.	38,700 lbs.	14mm	16.1 Kg	17.6 MT	19.5 MT
5/8"	2"	14.0 lbs.	49,500 lbs.	16mm	20.8 Kg	22.5 MT	24.9 MT

TECHNICAL SPECIFICATIONS:

CLASS II ROPE

SPECIFIC GRAVITY: 1.40

ELASTIC ELONGATION PERCENTAGE:

- At % of break strength
- 10% 0.49%
- 20% 0.78%
- 30% 0.98%

SPLICING PROCEDURES REQUIRED:

- EYE SPLICE – 12-Strand/Class II Rope
- END FOR END SPLICE – 12-Strand/Class II Rope

TECH-I2: HIGH STRENGTH AND HEAT RESISTANCE, WITH LOW STRETCH AND SUPERIOR FLEX-FATIGUE CHARACTERISTICS.

FEATURES:

- High strength/low stretch
- Flexible non rotational construction
- High heat resistance
- Easy to splice • Negligible creep/cold flow

APPLICATIONS:

- Deep water lift lines
- Towed or taut moored array systems

Tech-I2™ is a very high strength and heat resistant, non-rotational Samthane coated 12-strand single braid rope that offers the low stretch of an aramid fiber but with superior flex-fatigue. This Technora® fiber rope construction has negligible creep or cold flow characteristics and yields excellent control stability for equipment installations over a long period of time.



12-STRAND

Size Dia. Inches	Size Circ. Inches	Weight lbs. Per 100 FT.	SRT MBS/lbs.	Size Dia. mm	Weight KG Per 100 M	SRT MBS/Metric Tonnes	ISO/BS EN919 Strength/Metric Tonnes
1/8"	3/8"	0.6 lbs.	2,500 lbs.	3mm	0.9 Kg	1.1 MT	1.3 MT
3/16"	9/16"	1.3 lbs.	5,000 lbs.	5mm	1.9 Kg	2.3 MT	2.5 MT
1/4"	3/4"	1.9 lbs.	7,300 lbs.	6mm	2.8 Kg	3.3 MT	3.7 MT
5/16"	1"	3.2 lbs.	11,700 lbs.	8mm	4.8 Kg	5.3 MT	5.9 MT
3/8"	1-1/8"	4.3 lbs.	16,200 lbs.	9mm	6.4 Kg	7.3 MT	8.2 MT
7/16"	1-1/4"	6.7 lbs.	25,200 lbs.	11mm	10.0 Kg	11.4 MT	12.7 MT
1/2"	1-1/2"	8.3 lbs.	29,700 lbs.	12mm	11.9 Kg	13.5 MT	15.0 MT
5/8"	2"	13.5 lbs.	45,000 lbs.	16mm	20.1 Kg	20.4 MT	22.7 MT
3/4"	2-1/4"	19.3 lbs.	58,500 lbs.	18mm	28.7 Kg	26.5 MT	29.5 MT
7/8"	2-3/4"	25.3 lbs.	75,600 lbs.	22mm	37.7 Kg	34.3 MT	38.1 MT
1"	3"	31.1 lbs.	91,800 lbs.	24mm	46.3 Kg	41.6 MT	46.3 MT

TECHNICAL SPECIFICATIONS:

CLASS II ROPE

SPECIFIC GRAVITY: 1.39

ELASTIC ELONGATION PERCENTAGE:

- At % of break strength
- 10% 0.63%
- 20% 0.96%
- 30% 1.20%

SPLICING PROCEDURES REQUIRED:

- EYE SPLICE – 12-Strand/Class II Rope
- END FOR END SPLICE – 12-Strand/Class II Rope

MOORING LINES COMPARATIVE DATA SECTION

PRIMARY MOORING LINE COMPARISON

**SAMSON TO WIRE BY:
SIZE, STRENGTH
AND WEIGHT**

“THE LINES ARE EXTREMELY LIGHTWEIGHT COMPARED TO THE STEEL WIRE ROPES THEY REPLACED, MAKING IT EASY FOR CREW AND TERMINAL PERSONNEL TO HANDLE.”



Size	28mm [1-1/8"]	32mm [1-5/16"]	30mm [1-1/4"]	28mm [1-1/8"]	28mm [1-1/8"]
MBS Tonnes	60.3 MT	64.9 MT	58.1 MT	55.2 MT	59.0 MT
KG/100 M	47.5 Kg	56.4 Kg	53.5 Kg	345.0 Kg	345.0 Kg
Size	36mm [1-1/2"]	40mm [1-5/8"]	40mm [1-5/8"]	36mm [1-1/2"]	36mm [1-1/2"]
MBS Tonnes	93.0 MT	96.6 MT	96.6 MT	91.2 MT	97.6 MT
KG/100 M	76.9 Kg	87.1 Kg	86.3 Kg	570.0 Kg	570.0 Kg
Size	40mm [1-5/8"]	44mm [1-3/4"]	44mm [1-3/4"]	40mm [1-5/8"]	40mm [1-5/8"]
MBS Tonnes	115.7 MT	114.8 MT	117.5 MT	113.0 MT	121.0 MT
KG/100 M	97.0 Kg	104.8 Kg	103.4 Kg	704.0 Kg	704.0 Kg
Size	44mm [1-3/4"]	48mm [2"]	48mm [2"]	44mm [1-3/4"]	44mm [1-3/4"]
MBS Tonnes	137.0 MT	134.3 MT	140.6 MT	136.0 MT	146.0 MT
KG/100 M	116.7 Kg	124.1 Kg	125.7 Kg	851.0 Kg	851.0 Kg



PRIMARY MOORING LINE STRENGTH COMPARISON

STRENGTHS SHOWN IN METRIC TONNES

SIZE		AMSTEEL-BLUE		FORCE-8		DPX-75		PROTON 8	
Dia. Inches	Dia. mm	SRT MBS	ISO/BS EN919	SRT MBS	ISO/BS EN919	SRT MBS	ISO/BS EN919	SRT MBS	ISO/BS EN919
1-1/8"	28mm	60.3 MT	67.0 MT	50.8 MT	56.4 MT	48.1 MT	53.4 MT	31.3 MT	34.8 MT
1-1/4"	30mm	67.6 MT	75.1 MT	57.6 MT	64.0 MT	58.1 MT	64.5 MT	39.5 MT	43.8 MT
1-5/16"	32mm	75.3 MT	83.7 MT	64.9 MT	72.1 MT	67.6 MT	75.1 MT	47.2 MT	52.4 MT
1-3/8"	34mm	83.9 MT	93.2 MT	68.9 MT	76.6 MT	75.8 MT	84.2 MT	49.0 MT	54.4 MT
1-1/2"	36mm	93.0 MT	103.3 MT	79.8 MT	88.7 MT	81.2 MT	90.2 MT	56.7 MT	63.0 MT
1-5/8"	40mm	115.7 MT	128.5 MT	96.6 MT	107.4 MT	96.6 MT	107.4 MT	63.5 MT	70.6 MT
1-3/4"	44mm	137.0 MT	152.2 MT	114.8 MT	127.5 MT	117.5 MT	130.5 MT	86.2 MT	95.8 MT

P-7 PENDANTS FOR PRIMARY MOORING LINES

P-7 MOORING PENDANTS

PRODUCT CODE: 709



MOORING MASTER P-7

SAMSON SUGGESTS THE USE OF BRAIDED MOORING MASTER P-7 (100% POLYESTER) FOR PRIMARY MOORING LINE PENDANTS. THE EFFICIENT DESIGN OF P-7 PENDANTS ALLOWS SIGNIFICANT SIZE AND WEIGHT ADVANTAGES OVER CONVENTIONAL 8-BRAID PENDANTS; HIGHER STRENGTHS CAN ALLOW "DOWN-SIZING." P-7 MOORING PENDANTS MEET THE RECOMMENDATIONS OF OCIMF.

P-7 mooring pendants provide the energy absorption to minimize ship excursion in a mooring system, while holding up to the abuse of being dragged on piers and working on rough mooring hooks, cleats and bollards. P-7 has braided polyester strength members covered by a heavy-duty polyester jacket. The core provides the superior flex fatigue resistance for maximum service life, while the polyester jacket provides the protection necessary in rough working environments. P-7 pendants are available in single leg and strop configurations and can be connected to the primary mooring line by cow-hitching the soft eyes or with a mandrel shackle.



P-7 SINGLE LEG PENDANTS

SINGLE LEG:

Standard length is 11M OAL with a 2M soft eye one end and a 1M soft eye the other end. The vertex and splice area are urethane coated for added wear protection.

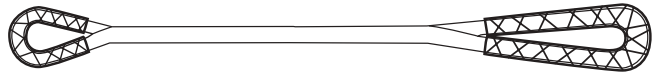

SIZING OF P-7 SINGLE LEG PENDANTS TO AMSTEEL-BLUE MOORING LINE SIZES BASED ON OCIMF PENDANT STRENGTH REQUIREMENTS

AmSteel-Blue Mooring Lines Size Dia. Inches	Size Dia. mm	AmSteel-Blue MBS Tonnes	OCIMF Required Pendant MBS Tonnes	Required P-7 Single Leg Rope Size	P-7 Single Leg MBS Tonnes	Approx. Weight/Unit Lbs. Kg
1"	24mm	44.5 MT	55.6 MT	1-7/8" 45mm	60.3 MT	65 lbs. 29.5 Kg
1-1/16"	26mm	53.5 MT	66.9 MT	2" 48mm	64.6 MT	70 lbs. 31.8 Kg
1-1/8"	28mm	60.3 MT	75.4 MT	2-1/8" 52mm	77.6 MT	75 lbs. 34.0 Kg
1-5/16"	32mm	75.3 MT	94.1 MT	2-3/8" 56mm	96.9 MT	85 lbs. 38.6 Kg
1-1/2"	36mm	93.0 MT	116.3 MT	2-5/8" 64mm	118.5 MT	110 lbs. 49.9 Kg
1-5/8"	40mm	115.7 MT	144.6 MT	3" 72mm	153.5 MT	140 lbs. 63.5 Kg
1-3/4"	44mm	137.0 MT	171.3 MT	See Strop	See Strop	See Strop

P-7 STROP PENDANTS

STROP:

Standard length is 11M OAL with 2M and 1M soft eyes formed by way of lashings. The body of the strop is lashed together 3M in from each eye lashing.

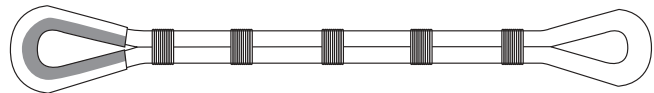

SIZING OF P-7 STROP PENDANTS TO AMSTEEL-BLUE MOORING LINE SIZES BASED ON OCIMF PENDANT STRENGTH REQUIREMENTS

AmSteel-Blue Mooring Lines Size Dia. Inches	Size Dia. mm	OCIMF Required Pendant MBS Tonnes	Required P-7 Rope Size for Strop Configuration	P-7 Single Leg Pendant MBS Tonnes	P-7 Strop Pendant MBS Tonnes	Approx. Weight/Unit Lbs. Kg
1"	24mm	55.6 MT	1-1/2" 36mm	38.6 MT	61.8 MT	70 lbs. 31.8 Kg
1-1/16"	26mm	66.9 MT	1-5/8" 40mm	45.4 MT	72.6 MT	80 lbs. 36.3 Kg
1-1/8"	28mm	75.4 MT	1-3/4" 44mm	52.6 MT	84.2 MT	90 lbs. 40.8 Kg
1-5/16"	32mm	94.1 MT	1-7/8" 45mm	60.3 MT	96.5 MT	100 lbs. 45.4 Kg
1-1/2"	36mm	116.3 MT	2-1/8" 52mm	77.6 MT	124.2 MT	120 lbs. 54.4 Kg
1-5/8"	40mm	144.6 MT	2-1/4" 56mm	87.1 MT	139.4 MT	135 lbs. 61.2 Kg
1-3/4"	44mm	171.3 MT	2-1/2" 60mm	107.5 MT	172.0 MT	160 lbs. 72.6 Kg

SECONDARY MOORING LINES

SECONDARY MOORING LINE STRENGTH COMPARISON

STRENGTHS SHOWN IN METRIC TONNES

		PROTON 8		ROUND PLAIT SSR-1200		ROUND PLAIT PNX	
Size Dia. Inches	Size Dia. mm	SRT MBS	ISO/BS EN919	SRT MBS	ISO/BS EN919	SRT MBS	ISO/BS EN919
1-5/8"	40mm	63.5 MT	70.6 MT	29.4 MT	32.7 MT	-	-
1-3/4"	44mm	86.2 MT	95.8 MT	34.3 MT	38.1 MT	-	-
2"	48mm	107.5 MT	119.4 MT	41.6 MT	46.3 MT	-	-
2-1/8"	52mm	125.6 MT	139.6 MT	49.0 MT	54.4 MT	-	-
2-1/4"	56mm	143.3 MT	159.3 MT	56.7 MT	63.0 MT	-	-
2-1/2"	60mm	179.6 MT	199.1 MT	64.9 MT	72.1 MT	53.1 MT	59.0 MT
2-5/8"	64mm	197.3 MT	219.2 MT	71.4 MT	79.6 MT	59.4 MT	66.0 MT
2-3/4"	68mm	245.9 MT	273.2 MT	83.5 MT	92.7 MT	64.0 MT	71.1 MT
3"	72mm	284.9 MT	316.5 MT	89.8 MT	99.8 MT	73.5 MT	81.6 MT



TENEX – TEC

SECONDARY MOORING LINE STOPPER

PRODUCT CODE: 825

Tenex-Tec is a twelve-strand Samthane coated, high tenacity polyester single braid that offers high strength, low stretch and outstanding abrasion resistance. Tenex-Tec makes an excellent mooring line stopper because during its initial use, the design will flex-conform to the specific mooring line rope construction and improve its holding capability. As Tenex-Tec wears, its COF increases even more. It should only be used with synthetic fiber secondary mooring lines, or mooring lines not on winches. Tenex-TEC should not be used on high performance synthetic ropes that have external outer fibers of low coefficient of friction material such as Dyneema fiber.

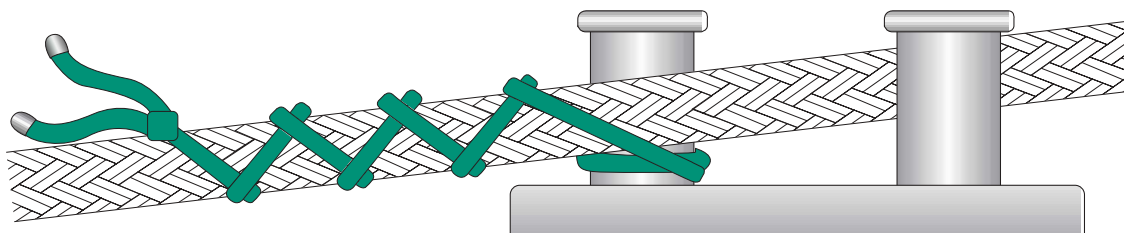

STOPPER STRENGTH COMPARISON

Size Dia. Inches	Weight Lbs. Per 100 FT.	SRT MBS/lbs.	ISO/BS EN919 Strength/lbs.	Size Dia. mm	Weight Lbs. Per 100 M	STR MBS/Tonnes	ISO/BS EN919 Strength/Tonnes
1-1/4"	55.0 lbs.	55,800 lbs.	62,000 lbs.	30mm	81.9 Kg	24.9 MT	27.7 MT

TUG ASSIST / MANEUVERING LINES



“FOR OVER A YEAR NOW WE HAVE SUBJECTED PROTON 8 TO THE MOST SEVERE SERVICE THAT A TOWBOAT ENGAGED IN THE DREDGING BUSINESS CAN DISH OUT... THE LIGHT WEIGHT, STRENGTH AND PROVEN DURABILITY OF PROTON 8 MAKE IT BY FAR, THE BEST LINE WE HAVE USED FOR OUR BUSINESS.”

SAMSON OFFERS SPECIFIC PRODUCTS TO MEET THE NEEDS OF VARYING TUG DESIGNS AND BOLLARD PULLS FOR CONVENTIONAL OR TRACTOR TUGS ASSIST/MANEUVERING LINES THAT ARE WORKED OFF DRUMS OR H-BITTS.

Our Sales and Engineering groups can assist by supplying detailed engineered solutions to improve rope performance and safety.

WHEN WORKING WITH H-BITTS:

Slippage and the effect of heat build up are critical factors when working with H-bitts. The main rope for use on H-bitts should have an outer working surface of polyester to provide the holding friction and heat protection necessary when surging the rope. To minimize the working line weight and maximize the wear of the shipboard connecting end, a floating light weight AmSteel-Blue pendant can be utilized.

FOR DRUM WORKING LINES:

Since gripping and heat resistance are not as critical, the higher strength and lighter weight of an all-Dyneema rope provide the best performance. These ropes are also used with a replaceable connecting pendant to insure maximum service life of the main working line.

DRUM WORKING LINE COMPARISON



Size Dia. Inches	Size Dia. mm	AmSteel-Blue		Neutron-8	
		Kg/100M	MBS Tonnes	Kg/100M	MBS Tonnes
6"	48mm	129.5 Kg	155.6 MT	133.6 Kg	183.7 MT
7"	56mm	172.6 Kg	219.5 MT	169.2 Kg	222.3 MT
8"	64mm	248.5 Kg	269.9 MT	230.2 Kg	295.7 MT
9"	72mm	306.6 Kg	339.3 MT	300.7 Kg	378.8 MT
10"	80mm	357.2 Kg	411.0 MT	352.8 Kg	452.7 MT

H-BITT WORKING LINE COMPARISON



Size Dia. Inches	Size Dia. mm	Proton-8		Round Plait SSR-I200	
		Kg/100M	MBS Tonnes	Kg/100M	MBS Tonnes
6"	48mm	147.3 Kg	107.5 MT	151.8 Kg	41.6 MT
7"	56mm	186.5 Kg	143.3 MT	202.4 Kg	56.7 MT
8"	64mm	256.6 Kg	197.3 MT	261.9 Kg	71.7 MT
9"	72mm	294.4 Kg	245.9 MT	343.8 Kg	89.8 MT
10"	80mm	377.9 Kg	284.9 MT	425.6 Kg	110.2 MT

TUG ASSIST / MANEUVERING LINE PENDANTS

TO ENSURE MAXIMUM SERVICE LIFE OF TUG ASSIST AND MANEUVERING LINES, SAMSON RECOMMENDS THE USE OF A SINGLE LEG OR STROP PENDANT.

The pendants will take the abuse of rough undressed chocks and bitts aboard the assisted vessel and allow the main assist lines to be maintained. The pendants can be connected by way of cow-hitching the 1 meter soft eye of the single leg or the strop to the main line soft eye. The strop configuration can be readjusted to share the wear over the strop length.

To protect the pendants, our Pro-Gard™ Eye Protectors for the pendant eyes can be easily installed in the field or at time of order—refer to page (35).

AMSTEEL-BLUE SINGLE-LEG PENDANT CONFIGURATION

SINGLE LEG PENDANT CONFIGURATION:

Standard overall length is 15.2M (50 FT.) with a 1M (3 Ft.) soft eye, for mating to main line, and a 2M (6 Ft.) soft eye for shipboard connection.

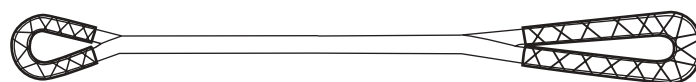

Eye-to-eye single leg connection.

Size Dia. Inches	Size Circ. Inches	Approx. Wt. Per Unit/ Lbs.	SRT MBS/Lbs.	Size Dia. mm	Approx. Wt. Per Unit/KG	SRT MBS/Metric Tonnes	ISO/BS EN919 Strength/Metric Tonnes
1-1/2"	4-1/2"	39.0 lbs.	205,000 lbs.	36mm	17.7 Kg	93.0 MT	103.3 MT
1-5/8"	5"	51.0 lbs.	255,000 lbs.	40mm	23.1 Kg	115.7 MT	128.5 MT
1-3/4"	5-1/2"	61.0 lbs.	302,000 lbs.	44mm	27.7 Kg	137.0 MT	152.2 MT
2"	6"	73.0 lbs.	343,000 lbs.	48mm	33.1 Kg	155.6 MT	172.9 MT
2-1/8"	6-1/2"	89.0 lbs.	411,000 lbs.	52mm	40.4 Kg	186.4 MT	207.1 MT
2-1/4"	7"	102.0 lbs.	484,000 lbs.	56mm	46.3 Kg	219.5 MT	243.9 MT
2-1/2"	7-1/2"	126.0 lbs.	529,000 lbs.	60mm	57.2 Kg	240.0 MT	266.6 MT
2-5/8"	8"	145.0 lbs.	595,000 lbs.	64mm	65.8 Kg	269.9 MT	299.9 MT
2-3/4"	8-1/2"	166.0 lbs.	662,000 lbs.	68mm	75.3 Kg	300.3 MT	333.6 MT
3"	9"	187.0 lbs.	748,000 lbs.	72mm	84.8 Kg	339.3 MT	377.0 MT
3-1/4"	10"	245.0 lbs.	906,000 lbs.	80mm	111.1 Kg	411.0 MT	456.6 MT

AMSTEEL-BLUE STROP PENDANT CONFIGURATION

SINGLE LEG STROP CONFIGURATION:

Standard overall length is 15.2M (50 Ft.). Strop strengths are 1.6 x single leg rope strengths.

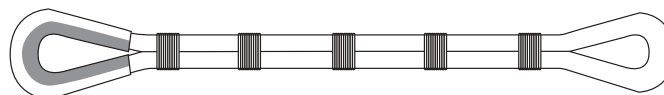

Strop to main line connection.

Rope Size Dia. Inches	Rope Size Circ. Inches	Approx. Strop Wt. Per Unit/Lbs.	SRT MBS/Lbs.	Rope Size Dia. mm	Strop Wt. Per Unit/KG	SRT MBS/Metric Tonnes	ISO/BS EN919 Strength/Metric Tonnes
1-1/4"	3-3/4"	41.0 lbs.	238,000 lbs.	30mm	18.6 Kg	108.0 MT	120.0 MT
1-5/16"	4"	48.0 lbs.	266,000 lbs.	32mm	21.8 Kg	120.7 MT	134.1 MT
1-1/2"	4-1/2"	60.0 lbs.	328,000 lbs.	36mm	27.2 Kg	148.8 MT	165.3 MT
1-5/8"	5"	78.0 lbs.	408,000 lbs.	40mm	35.4 Kg	185.1 MT	205.7 MT
1-3/4"	5-1/2"	93.0 lbs.	483,000 lbs.	44mm	42.2 Kg	219.1 MT	243.4 MT
2"	6"	111.0 lbs.	549,000 lbs.	48mm	50.3 Kg	249.0 MT	276.7 MT
2-1/8"	6-1/2"	134.0 lbs.	658,000 lbs.	52mm	60.8 Kg	298.5 MT	331.7 MT
2-1/4"	7"	153.0 lbs.	774,000 lbs.	56mm	69.4 Kg	351.1 MT	390.1 MT
2-1/2"	7-1/2"	186.0 lbs.	846,000 lbs.	60mm	84.4 Kg	383.7 MT	426.3 MT
2-5/8"	8"	214.0 lbs.	952,000 lbs.	64mm	97.1 Kg	431.8 MT	479.8 MT

SAMSON ENGINEERED SOLUTIONS:

PUTTING THE STRENGTH OF SAMSON RESEARCH AND DEVELOPMENT TO WORK ON REAL WORLD PROBLEMS.

At Samson, the traditionally lab based function of research and development is supplemented with real world experience: bringing the empirical in direct contact with the scientific. Sales and engineering work together not just to adapt an existing product to a customer's problem, but, if necessary, to develop new products and new solutions to operational problems. That's application engineering.

Projects are assigned an application engineer to assist in analyzing the problem and assess possible solutions. Is there an existing product that fits the requirements? Research and development identifies potential fibers or combinations of fibers in specific constructions that could be applied as solutions. All products are fully evaluated and tested to ensure performance.

The head of research and development at Samson can be found at the site of the problem as often as he's found in the lab, making certain the product is performing to expectations.



When products are installed, Samson's application engineer is there to assist. Training crews to inspect the rope, what to look for, and how to evaluate it while in use is a critical part of making certain the rope performs as expected. Even providing retirement criteria and documentation. It's all part of the process of developing the best solution to real world problems. It's all part of the strength of Samson.

The results are products proven to outperform the alternatives and contribute directly to significant savings in operational costs. Products developed as solutions to operational problems.

In partnership with the customer, Samson assisted in developing training and testing programs to aid in the creation of:

- Inspection and retirement guidelines
- Specific rope manuals for ships, crews, vessel operations management, and purchasing
- Product information and safety handling guidelines

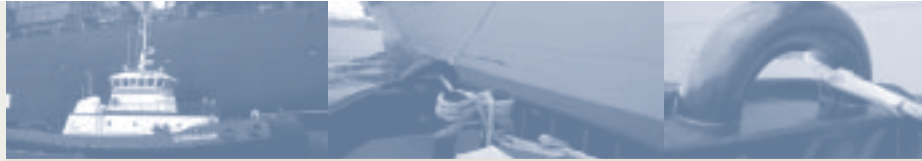

SAMSON ENGINEERED SOLUTIONS.

PROTON 8

“For over a year now we have subjected Proton 8 to the most severe service that a towboat engaged in the dredging business can dish out. It has been bent around bitts, cleats, threaded through the bullnose and exposed to burning from capstan surge. We have doubled it and used it as a strap, exposed it to severe shock and have even used it to tie up dockside subjecting it to abrasion from facilities in various states of disrepair. A close inspection reveals that the core fibers are in excellent condition while the outer fibers are worn but still very much intact. The original line is still in use daily. The light weight, strength and proven durability of Proton 8 make it by far, the best line we have used for our business.”

TUG ASSIST ROPE PROBLEMS

Not every tug operating today employs the high bollard pull or new winch machinery of modern tractor tugs. There are many tugs which need to work off H-bitts. Unfortunately, small diameter Dyneema HMPE fiber ropes such as Amsteel-Blue have too low a coefficient of friction to properly grip an H-bitt during tug work. Yet to reach the necessary strengths to work these tugs, large diameter, and heavy polyester or polyester/polypro “combo” have been in use. To handle these huge lines, several crew members must be used in deployment and retrieval. To control escalating costs and reduce crew rope handling injuries, a new “combo” rope – Proton 8 was developed.





THE PROBLEM

Meet the demand for a lightweight, high strength; low water absorption braided torque-free construction tug and barge working rope.

1. *Conventional polyester or polyester/polypro "combo" ropes are readily available and inexpensive on initial capital purchase price. However these false cost savings do not adequately address safety and performance concerns*

- Too difficult to handle and store onboard tug
- Absorb water making them heavier after first use
- Require more than one crew member to deploy and retrieve due to high weight and diameter
- Require a large diameter to reach necessary strength to handle ships; based on tug bollard pull ratings
- Wear very quickly due to their poor abrasion and cut resistance properties and poor UV resistance



THE SOLUTION

Marry the high strength, excellent cycle loading performance properties of Dyneema synthetic fiber with the necessary higher coefficient of friction properties of polyester. Proton 8 provides a strand surface of high heat resistance and high grip of polyester. Yet the majority of the rope design is Dyneema SK-75 HMPE fiber which provides the necessary properties needed to create a lightweight, small diameter working rope.

1. *Strength and performance*

- Proton 8 is over twice the strength of a comparable size 100% polyester rope. It is four times the strength of a comparable size polyester/polypro "combo" rope
- Proton 8 has much less elastic elongation than either rope.
- Proton 8 has proven to have the "gripping" properties of a 100% polyester rope, making it an excellent replacement for H-bitt work. (By "down-sizing" from polyester or polyester/polypro "combo" ropes, the tug operator can also get more wraps on his capstan winch or H-bitt than the larger diameter conventional ropes.)

2. *Safety*

- Proton 8 allows the tug operator to "down-size" to a lighter weight smaller diameter rope. The flexible 8-strand torque-free construction is "user-friendly" during deployment and retrieval. This all adds up to less rope related handling injuries.
- As a secondary tanker mooring line, the high strength in a small diameter size means less crew handling injuries during deployment and retrieval.
- Proton-8 has very low water absorption – leading to less lifting and back injuries.

3. *Economic savings from rope performance:*

- Safety benefits can be difficult to quantify. However, they remain key components in the "bottom line" profitability of a tug operator. Proton 8 will lead to less rope handling injuries.
- The cut and abrasion resistance of Proton 8 makes it an excellent candidate for extremely tough applications such as dredge and marine construction applications.





SAMSON ENGINEERED SOLUTIONS:

AMSTEEL-BLUE

“The AmSteel-Blue lines have been in service aboard our vessels for seven years, with very successful results. The lines are extremely lightweight compared to the steel wire ropes they replaced, making it easy for crew and terminal personnel to handle. This has resulted in a significant decline in injuries attributed to the mooring process. The lighter weight has also contributed to quicker mooring and unmooring times. The AmSteel-Blue lines require little maintenance, and are proving to be quite robust in service life with little if any loss of strength. In fact, we anticipate their useful service life to be several times greater than steel wire ropes.”



WIRE ROPE MOORING PROBLEMS

The high number and cost of mooring related injuries caused a leading worldwide oil/gas marine transport company to search for an alternative to wire rope. With a large fleet and many crew members, it was in their best interest to provide a better mooring solution.

THE PROBLEM(S)

1. **Wire rope causes major safety problems to a ship mooring operation:**
 - Crew injuries due to high weight and inflexibility of the mooring line
2. **Wire rope has many “hidden” operational costs:**
 - Constant re-lubrication is environmentally unsound, highly regulated & costly
 - Short service life – cannot handle severe bending radii and has low cycle loading properties
 - Environmental damage and abrasion damage to ship’s hardware
 - Higher repair/maintenance costs – cannot be repaired or re-terminated without mechanical equipment
 - Requires more crew members at each mooring operation “station”
3. **Industry Guidelines and Mooring Regulations:**
 - Most terminals and shipping companies refer to their trade organization OCIMF (Oil Companies International Marine Forum) for mooring guide lines. At the time of this investigation into a wire rope replacement mooring line, synthetic lines had not yet been “approved” for recommendation by OCIMF.





THE SOLUTION

Samson worked with this customer for over five years of field testing and evaluations to document and quantify the benefits of synthetic rope mooring systems. AmSteel-Blue primary mooring lines met the key criteria needed for justification of capital and maintenance expense for the fleet.

1. **Strength and performance (e.g elasticity)**

- Wire rope is the standard for both
- AmSteel-Blue provided a size for size replacement to wire rope with proven performance and reliability

2. **Safety: Significant reduction in crew injuries over the last five years**

- Hand injuries – no more wire rope fish-hooks
- Back injuries – AmSteel-Blue is only 1/7th the weight of an equal strength wire rope

3. **Economic savings from rope performance:**

Light weight handling provides faster mooring operation times (up to 2/3rd reduction in time)

- With fewer crew personnel needed
- Significantly reduces the risk time frame for crew injury
- Reduced tug ship assist costs
- Translates into faster loading & off-loading times – providing more sailing time / possibly more trips

4. **Durability of rope has lead to:**

- 2 – 3 times (or more) the service life than wire rope

5. **Significant reduction in cost of end-for-ending or termination time and costs**

- Eliminates employment of spooling trucks and personnel
- New eyes can easily be re-spliced while on spool

6. **Less damage to ship equipment**

- Reduces repairs on winches, rollers, chocks (no metal-to-metal damage caused by wire rope)

7. **Environmental savings**

- Eliminates fears of illegal discharge of chemicals from wire rope mooring line lube into the sea and harbors

Samson research and development and application engineers worked directly with the operator for five years field testing and documenting AmSteel-Blue as a direct replacement for wire rope mooring systems. The resulting data allowed the operator's committee to justify replacing all wire mooring systems throughout their fleet. Getting the customer to approve of the product benefits was only a part of the story.

IN THIS CASE, SAMSON ASSISTED IN OBTAINING OCIMF ACCEPTANCE OF SYNTHETIC MOORING LINES AS AN APPROVED ALTERNATIVE TO WIRE ROPE.

The result was the publication in 2002 of the OCIMF manual – *Guidelines on the use of high-modulus synthetic fibre ropes as mooring lines on large tankers*. First Edition 2002 – Witherbys Publishing. Working jointly with the customer, terminals were presented information and lines to facilitate the decision to allow tankers to use the new synthetic systems.



ROUND PLAIT SSR-I200: OUR BEST BLENDED ROPE, A 12-STRAND BRAID WITH THE WEAR RESISTANCE AND STRENGTH OF AN ALL POLYESTER ROPE WITH SIGNIFICANTLY LESS HANDLING WEIGHT.

FEATURES:

- High wear resistance on H-bitts and capstans
- Excellent heat resistance for rendering on H-bitts or capstans
- Firm smooth running flexibility
- 15-18% Lighter than all polyester ropes

APPLICATIONS:

- Secondary mooring lines
- Tug boat H-bitt working lines
- Barge/dredge working lines
- ATB working lines

A 12-strand braided rope that has the wear resistance and strength of an all Polyester rope with significantly less handling weight. This is accomplished through the unique design of a plied yarn construction utilizing a combination of polyester fiber with our proprietary Ultra Blue bi-polymer fiber in each yarn of the strand. Since the construction minimizes the amount of polyester fiber and relies on the lightweight non water absorbing features of the Ultra Blue fiber, it has significant dry weight and wet working weight advantages.

Round Plait SSR-1200™ has a smooth, non-rotational construction with an excellent coefficient of friction for working off H-bitts for Tug Assist Lines on conventional tugs or tractor tugs without winch drums. A special marine finish is added to enhance SSR-1200's performance.



ROUND PLAIT

ROUND PLAIT SSR-I200

PRODUCT CODE: 416

TECHNICAL SPECIFICATIONS:

CLASS I ROPE

SPECIFIC GRAVITY:

1.20

ELASTIC ELONGATION PERCENTAGE:

At % of break strength

10% 1.46%

20% 2.58%

30% 4.04%

SPLICING PROCEDURES REQUIRED:

- EYE SPLICE – Round Plait/Class I Rope
- END FOR END SPLICE – Round Plait/Class I Rope

Size Dia. Inches	Size Circ. Inches	Weight lbs. Per 100 FT.	SRT MBS/lbs.	Size Dia. mm	Weight KG Per 100 M	SRT MBS/Metric Tonnes	ISO/BS EN919 Strength/Metric Tonnes
3/4"	2-1/4"	16.0 lbs.	14,400 lbs.	18mm	23.8 Kg	6.5 MT	7.3 MT
7/8"	2-3/4"	24.0 lbs.	21,600 lbs.	22mm	35.7 Kg	9.8 MT	10.9 MT
1"	3"	30.0 lbs.	25,200 lbs.	24mm	44.6 Kg	11.4 MT	12.7 MT
1-1/8"	3-1/2"	35.0 lbs.	32,400 lbs.	28mm	52.1 Kg	14.7 MT	16.3 MT
1-1/4"	3-3/4"	39.0 lbs.	37,800 lbs.	30mm	58.0 Kg	17.1 MT	19.1 MT
1-5/16"	4"	47.0 lbs.	43,200 lbs.	32mm	69.9 Kg	19.6 MT	21.8 MT
1-1/2"	4-1/2"	60.0 lbs.	54,000 lbs.	36mm	89.3 Kg	24.5 MT	27.2 MT
1-5/8"	5"	72.0 lbs.	64,800 lbs.	40mm	107.2 Kg	29.4 MT	32.7 MT
1-3/4"	5-1/2"	84.0 lbs.	75,600 lbs.	44mm	125.0 Kg	34.3 MT	38.1 MT
2"	6"	102.0 lbs.	91,800 lbs.	48mm	151.8 Kg	41.6 MT	46.3 MT
2-1/8"	6-1/2"	120.0 lbs.	108,000 lbs.	52mm	178.6 Kg	49.0 MT	54.4 MT
2-1/4"	7"	136.0 lbs.	125,000 lbs.	56mm	202.4 Kg	56.7 MT	63.0 MT
2-1/2"	7-1/2"	150.0 lbs.	143,000 lbs.	60mm	238.1 Kg	64.9 MT	72.1 MT
2-5/8"	8"	176.0 lbs.	158,000 lbs.	64mm	261.9 Kg	71.7 MT	79.6 MT
2-3/4"	8-1/2"	199.0 lbs.	184,000 lbs.	68mm	296.2 Kg	83.5 MT	92.7 MT
3"	9"	231.0 lbs.	198,000 lbs.	72mm	343.8 Kg	89.8 MT	99.8 MT
3-1/4"	10"	286.0 lbs.	243,000 lbs.	80mm	425.6 Kg	110.2 MT	122.5 MT
3-5/8"	11"	342.0 lbs.	306,000 lbs.	88mm	509.0 Kg	138.8 MT	154.2 MT
4"	12"	413.0 lbs.	369,000 lbs.	96mm	614.6 Kg	167.4 MT	186.0 MT



ROUND PLAIT



ROUND PLAIT POLYESTER: A DURABLE 12-STRAND WORK HORSE

WITH EXCELLENT FLEX-FATIGUE LIFE.

FEATURES:

- High heat and wear resistance
- Low elastic or working elongation
- High strength
- Excellent working flexibility

APPLICATIONS:

- Tug H-bitt working lines
- ATB working lines
- Mooring pendants

RP12 Polyester™ has been a standard of performance for years in the tug and mooring industry. The firm strand and smooth construction of this product with low elongation/high tenacity polyester fiber create a durable work horse that has excellent flex-fatigue life.

The round plait construction allows a conforming surface contact with an all polyester fiber content that creates high heat resistance and excellent rendering capabilities while giving positive working control. For installing eye splices, Round Plait Polyester is easily tuck spliced as are all other Round Plait constructions.

ROUND PLAIT POLYESTER

PRODUCT CODE: 402

TECHNICAL SPECIFICATIONS:

CLASS I ROPE

SPECIFIC GRAVITY:
1.38

ELASTIC ELONGATION PERCENTAGE:

- At % of break strength
- 10% 1.7%
 - 20% 2.7%
 - 30% 3.9%

SPLICING PROCEDURES REQUIRED:

- EYE SPLICE – Round Plait/Class I Rope
- END FOR END SPLICE – Round Plait/Class I Rope

Size Dia. Inches	Size Circ. Inches	Weight lbs. Per 100 FT.	SRT MBS/lbs.	Size Dia. mm	Weight KG Per 100 M	SRT MBS/Metric Tonnes	ISO/BS EN919 Strength/Metric Tonnes
3/4"	2-1/4"	18.8 lbs.	15,700 lbs.	18mm	28.0 Kg	7.1 MT	7.9 MT
7/8"	2-3/4"	28.1 lbs.	23,600 lbs.	22mm	41.8 Kg	10.7 MT	11.9 MT
1"	3"	35.1 lbs.	27,500 lbs.	24mm	52.2 Kg	12.5 MT	13.9 MT
1-1/8"	3-1/2"	41.1 lbs.	35,300 lbs.	28mm	61.2 Kg	16.0 MT	17.8 MT
1-1/4"	3-3/4"	45.8 lbs.	41,200 lbs.	30mm	68.2 Kg	18.7 MT	20.8 MT
1-5/16"	4"	54.9 lbs.	47,100 lbs.	32mm	81.7 Kg	21.4 MT	23.7 MT
1-1/2"	4-1/2"	71.0 lbs.	58,900 lbs.	36mm	105.7 Kg	26.7 MT	29.7 MT
1-5/8"	5"	84.8 lbs.	70,700 lbs.	40mm	126.2 Kg	32.1 MT	35.6 MT
1-3/4"	5-1/2"	98.7 lbs.	82,400 lbs.	44mm	146.9 Kg	37.4 MT	41.5 MT
2"	6"	120.0 lbs.	99,900 lbs.	48mm	178.6 Kg	45.3 MT	50.3 MT
2-1/8"	6-1/2"	141.0 lbs.	118,000 lbs.	52mm	209.8 Kg	53.5 MT	59.5 MT
2-1/4"	7"	160.0 lbs.	136,000 lbs.	56mm	238.1 Kg	61.7 MT	68.5 MT
2-1/2"	7-1/2"	188.0 lbs.	159,000 lbs.	60mm	279.8 Kg	72.1 MT	80.1 MT
2-5/8"	8"	207.0 lbs.	176,000 lbs.	64mm	308.1 Kg	79.8 MT	88.7 MT
2-3/4"	8-1/2"	234.0 lbs.	200,000 lbs.	68mm	348.2 Kg	90.7 MT	100.8 MT
3"	9"	272.0 lbs.	230,000 lbs.	72mm	404.8 Kg	104.3 MT	115.9 MT
3-1/4"	10"	337.0 lbs.	278,000 lbs.	80mm	501.5 Kg	126.1 MT	140.1 MT
3-5/8"	11"	402.0 lbs.	338,000 lbs.	88mm	598.3 Kg	153.3 MT	170.4 MT
4"	12"	486.0 lbs.	405,000 lbs.	96mm	723.3 Kg	183.7 MT	204.1 MT

ROUND PLAIT POLYESTER™



ROUND PLAIT ULTRA BLUE: PROPRIETARY BI-POLYMER OLEFIN IN A FIRM, ROUND 12-STRAND WITH MORE THAN TWICE THE WEAR LIFE OF STANDARD POLYPROPYLENE.

FEATURES:

- High strength floating line
- Flexible non rotational construction
- Firm strand formation for maximum wear resistance
- Good UV resistance

APPLICATIONS:

- Floating emergency barge trailer lines
- Mooring lines
- Tug and barge tie-up lines

This working or mooring line uses Samson's Round Plait construction to provide better wear characteristics than 8-strand ropes. Our proprietary blue olefin bi-polymer yarn provides 35-40% higher strength than a conventional olefin rope. The Ultra Blue fiber enhances the gripping capability by developing distinct outer surface fuzz that also acts as a wear protector for the subsurface fibers.



ROUND PLAIT

Size Dia. Inches	Size Circ. Inches	Weight lbs. Per 100 FT.	SRT MBS/lbs.	Size Dia. mm	Weight KG Per 100 M	SRT MBS/Metric Tonnes	ISO/BS EN919 Strength/Metric Tonnes
5/8"	2"	9.5 lbs.	8,600 lbs.	16mm	14.1 Kg	3.9 MT	4.3 MT
3/4"	2-1/4"	12.5 lbs.	12,200 lbs.	18mm	18.6 Kg	5.5 MT	6.1 MT
7/8"	2-3/4"	17.0 lbs.	18,000 lbs.	22mm	25.3 Kg	8.2 MT	9.1 MT
1"	3"	23.3 lbs.	22,500 lbs.	24mm	34.7 Kg	10.2 MT	11.3 MT
1-1/8"	3-1/2"	25.5 lbs.	24,300 lbs.	28mm	37.9 Kg	11.0 MT	12.2 MT
1-1/4"	3-3/4"	35.0 lbs.	34,200 lbs.	30mm	52.1 Kg	15.5 MT	17.2 MT
1-5/16"	4"	38.0 lbs.	38,700 lbs.	32mm	56.6 Kg	17.6 MT	19.5 MT
1-1/2"	4-1/2"	44.0 lbs.	42,300 lbs.	36mm	65.5 Kg	19.2 MT	21.3 MT
1-5/8"	5"	54.0 lbs.	54,900 lbs.	40mm	80.4 Kg	24.9 MT	27.7 MT
1-3/4"	5-1/2"	64.0 lbs.	65,700 lbs.	44mm	95.2 Kg	29.8 MT	33.1 MT
2"	6"	74.0 lbs.	76,500 lbs.	48mm	110.1 Kg	34.7 MT	38.6 MT
2-1/8"	6-1/2"	87.0 lbs.	85,500 lbs.	52mm	129.5 Kg	38.8 MT	43.1 MT
2-1/4"	7"	101.0 lbs.	99,000 lbs.	56mm	150.3 Kg	44.9 MT	49.9 MT
2-1/2"	7-1/2"	117.0 lbs.	117,000 lbs.	60mm	174.1 Kg	53.1 MT	59.0 MT
2-5/8"	8"	133.0 lbs.	131,000 lbs.	64mm	197.9 Kg	59.4 MT	66.0 MT
2-3/4"	8 1/2"	148.0 lbs.	141,000 lbs.	68mm	220.3 Kg	64.1 MT	71.2 MT
3"	9"	180.0 lbs.	162,000 lbs.	72mm	251.5 Kg	73.5 MT	81.6 MT
3-1/4"	10"	215.0 lbs.	204,000 lbs.	80mm	320.0 Kg	92.5 MT	102.8 MT
3-5/8"	11"	250.0 lbs.	239,000 lbs.	88mm	372.1 Kg	108.4 MT	120.5 MT
4"	12"	297.0 lbs.	284,000 lbs.	96mm	442.0 Kg	128.8 MT	143.1 MT

ROUND PLAIT ULTRA BLUE

PRODUCT CODE: 333

TECHNICAL SPECIFICATIONS:

CLASS I ROPE

SPECIFIC GRAVITY:

.94

ELASTIC ELONGATION PERCENTAGE:

At % of break strength

10% 1.31%

20% 2.27%

30% 3.27%

SPLICING PROCEDURES REQUIRED:

- EYE SPLICE – Round Plait/Class I Rope
- END FOR END SPLICE – Round Plait/Class I Rope

SAMSON



ROUND PLAIT



ROUND PLAIT PNX: A FLOATING 12-STRAND BRAIDED NON ROTATIONAL ROPE WITH SUPERIOR WEAR AND HANDLING CHARACTERISTICS.

FEATURES:

- Floating non rotational combination rope
- Good UV resistance
- Excellent Flex and wear resistance

APPLICATIONS:

- Mooring lines
- Tie-up lines
- Messenger pick up lines

The firm Round Plait construction with alternating yarns of high tenacity polyester and Ultra Blue fiber in each strand create an extremely light weight, durable product. Samson Pro-Gard marine finish is applied to further enhance long term durability and flexibility of the PNX construction.

The smooth construction allows even surface wear and the ease of using a standard tuck splice for eye splices.

ROUND PLAIT PNX

PRODUCT CODE: 415

TECHNICAL SPECIFICATIONS:

CLASS I ROPE

SPECIFIC GRAVITY:
.99

ELASTIC ELONGATION PERCENTAGE:

- At % of break strength
- 10% 2.3%
- 20% 3.1%
- 30% 5.0%

SPLICING PROCEDURES REQUIRED:

- EYE SPLICE – Round Plait/Class I Rope
- END FOR END SPLICE – Round Plait/Class I Rope

Size Dia. Inches	Size Circ. Inches	Weight lbs. Per 100 FT.	SRT MBS/lbs.	Size Dia. mm	Weight KG Per 100 M	SRT MBS/Metric Tonnes	ISO/BS EN919 Strength/Metric Tonnes
2-1/2"	7 1/2"	119.0 lbs.	117,000 lbs.	60mm	177.1 Kg	53.1 MT	59.0 MT
2-5/8"	8"	133.0 lbs.	131,000 lbs.	64mm	197.9 Kg	59.4 MT	66.0 MT
2-3/4"	8 1/2"	154.0 lbs.	141,000 lbs.	68mm	229.2 Kg	64.0 MT	71.1 MT
3"	9"	178.0 lbs.	162,000 lbs.	72mm	264.9 Kg	73.5 MT	81.6 MT



PRODUCT SPOTLIGHT

Samson PNX design technology has been in constant use since the 1970's. The working synergy of Ultra-Blue olefin fiber and polyester create our most popular secondary mooring line. Round Plait PNX is an extremely popular mooring line for cruise ships, container ships, or tankers. It works well on drums or on H-bitts.

ROUND PLAIT PNX™

2-IN-1 STABLE BRAID: A TIME PROVEN, TOUGH 100% POLYESTER DOUBLE BRAID WITH EXCELLENT CONTROLLED WORKING ELONGATION.

FEATURES:

- High wear and heat resistance
- Excellent Flex-Fatigue service life
- Firm flexibility
- Low working elongation

APPLICATIONS:

- Navy traction winch tow lines
- Constant tension winch mooring lines
- Secondary mooring lines
- Deep water anchoring or lifting lines

Samson Parallay™ construction orients all fibers to the axis of the rope for maximum strength and wear resistance. The braided core and cover both contribute to the strength and firm hand, while remaining fully spliceable.

This product works very well on winch drums or has the non rotational flexibility to be faked on deck for deep anchor deployment. It has shown its durability and stowage flexibility on traction winch towing applications utilizing below deck rope lockers.

Stable Braid™ is a time proven, tough rope with excellent controlled working elongation. Wet service life is enhanced by the use of Pro-Gard™ marine finish.



DOUBLE BRAID

Size Dia. Inches	Size Circ. Inches	Weight lbs. Per 100 FT.	SRT MBS/lbs.	Size Dia. mm	Weight KG Per 100 M	SRT MBS/Metric Tonnes	ISO/BS EN919 Strength/Metric Tonnes
1/4"	3/4"	2.1 lbs.	2,000 lbs.	6mm	3.1 Kg	0.9 MT	1.0 MT
5/16"	1"	3.2 lbs.	3,100 lbs.	8mm	4.8 Kg	1.4 MT	1.6 MT
3/8"	1-1/8"	4.5 lbs.	4,800 lbs.	9mm	6.7 Kg	2.2 MT	2.4 MT
7/16"	1-1/4"	6.1 lbs.	6,500 lbs.	11mm	9.1 Kg	2.9 MT	3.3 MT
1/2"	1-1/2"	8.2 lbs.	8,800 lbs.	12mm	12.2 Kg	4.0 MT	4.4 MT
9/16"	1-3/4"	11.0 lbs.	11,300 lbs.	14mm	16.4 Kg	5.1 MT	5.7 MT
5/8"	2"	14.0 lbs.	13,900 lbs.	16mm	20.8 Kg	6.3 MT	7.0 MT
3/4"	2-1/4"	18.0 lbs.	17,300 lbs.	18mm	26.8 Kg	7.8 MT	8.7 MT
7/8"	2-3/4"	27.1 lbs.	25,400 lbs.	22mm	40.3 Kg	11.5 MT	12.8 MT
1"	3"	34.0 lbs.	33,300 lbs.	24mm	50.6 Kg	15.1 MT	16.8 MT
1-1/8"	3-1/2"	45.3 lbs.	41,000 lbs.	28mm	67.4 Kg	18.6 MT	20.7 MT
1-1/4"	3-3/4"	53.9 lbs.	48,700 lbs.	30mm	80.2 Kg	22.1 MT	24.5 MT
1-5/16"	4"	60.8 lbs.	55,000 lbs.	32mm	90.5 Kg	24.9 MT	27.7 MT
1-1/2"	4-1/2"	73.3 lbs.	63,800 lbs.	36mm	109.1 Kg	28.9 MT	32.2 MT
1-5/8"	5"	85.9 lbs.	74,100 lbs.	40mm	127.8 Kg	33.6 MT	37.3 MT
1-3/4"	5-1/2"	104.0 lbs.	88,400 lbs.	44mm	154.8 Kg	40.1 MT	44.6 MT
2"	6"	124.0 lbs.	105,400 lbs.	48mm	184.5 Kg	47.8 MT	53.1 MT
2-1/8"	6-1/2"	147.0 lbs.	123,300 lbs.	52mm	218.7 Kg	55.9 MT	62.1 MT
2-1/4"	7"	173.0 lbs.	141,100 lbs.	56mm	257.5 Kg	64.0 MT	71.1 MT
2-1/2"	7-1/2"	196.0 lbs.	161,500 lbs.	60mm	291.7 Kg	73.3 MT	81.4 MT
2-5/8"	8"	225.0 lbs.	180,200 lbs.	64mm	334.8 Kg	81.7 MT	90.8 MT
2-3/4"	8-1/2"	246.0 lbs.	198,900 lbs.	68mm	366.1 Kg	90.2 MT	100.2 MT
3"	9"	300.0 lbs.	236,300 lbs.	72mm	446.5 Kg	107.2 MT	119.1 MT
3-1/4"	10"	375.0 lbs.	291,600 lbs.	80mm	558.1 Kg	132.3 MT	147.0 MT
3-5/8"	11"	450.0 lbs.	346,000 lbs.	88mm	669.7 Kg	156.9 MT	174.4 MT
4"	12"	525.0 lbs.	399,500 lbs.	96mm	781.3 Kg	181.2 MT	201.3 MT
4-1/4"	13"	589.0 lbs.	453,100 lbs.	104mm	876.5 Kg	205.5 MT	228.4 MT
4-5/8"	14"	689.0 lbs.	523,600 lbs.	112mm	1025.4 Kg	237.5 MT	263.9 MT
5"	15"	788.0 lbs.	593,300 lbs.	120mm	1172.7 Kg	269.1 MT	299.0 MT

2-IN-1 STABLE BRAID

PRODUCT CODE: 506

TECHNICAL SPECIFICATIONS:

CLASS I ROPE

SPECIFIC GRAVITY:

1.38

ELASTIC ELONGATION PERCENTAGE:

At % of break strength

10% 1.1%

20% 1.7%

30% 2.7%

SPlicing PROCEDURES REQUIRED:

- EYE SPLICE –
Double Braid/Class I Rope
- END FOR END SPLICE –
Double Braid/Class I Rope



DOUBLE BRAID

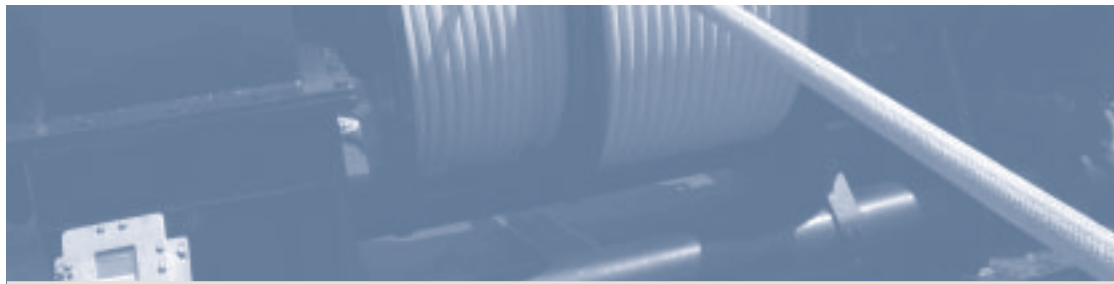

2-IN-1 SUPER STRONG NYLON: DOUBLE BRAIDED NYLON ROPE WITH HIGH STRENGTH, HIGH STRETCH AND SHOCK MITIGATION.

FEATURES:

- High energy absorption/shock mitigation
- Excellent wear resistance
- Highly flexible – easy to handle
- High strength to weight ratio

APPLICATIONS:

- US Navy-Coast Guard mooring lines
- US Navy-Coast Guard tow lines
- Deep water buoy anchor lines
- Towed array stretch section line

Samson Parallay™ construction orients all fibers to the axis of the rope for maximum strength and wear resistance. The braided core and cover both contribute to the strength and firm hand, while remaining fully spliceable. This product works very well on capstans or has the non rotational flexibility to be faked on deck for deep buoy anchor deployment. It has shown its durability and stowage flexibility on traction winch towing applications utilizing below deck rope lockers.

Super Strong has a long history of reliable performance that has met the strength and energy absorption requirements for diverse dynamic applications in the commercial marine industry.

2-IN-1 SUPER STRONG

PRODUCT CODE: 472

TECHNICAL SPECIFICATIONS:

CLASS I ROPE

SPECIFIC GRAVITY:

1.14

ELASTIC ELONGATION PERCENTAGE:

At % of break strength

10% 3.0%

20% 5.3%

30% 6.7%

SPLICING PROCEDURES REQUIRED:

- EYE SPLICE – Double Braid/Class I Rope
- END FOR END SPLICE – Double Braid/Class I Rope

Size Dia. Inches	Size Circ. Inches	Weight lbs. Per 100 FT.	SRT MBS/lbs.	Size Dia. mm	Weight KG Per 100 M	SRT MBS/Metric Tonnes	ISO/BS EN919 Strength/Metric Tonnes
1/4"	3/4"	1.6 lbs.	2,000 lbs.	6mm	2.4 Kg	0.9 MT	1.0 MT
5/16"	1"	2.6 lbs.	2,900 lbs.	8mm	3.9 Kg	1.3 MT	1.5 MT
3/8"	1-1/8"	3.7 lbs.	4,200 lbs.	9mm	5.5 Kg	1.9 MT	2.1 MT
7/16"	1-1/4"	5.1 lbs.	5,600 lbs.	11mm	7.6 Kg	2.5 MT	2.8 MT
1/2"	1-1/2"	6.6 lbs.	7,200 lbs.	12mm	9.8 Kg	3.3 MT	3.6 MT
5/8"	2"	12.0 lbs.	12,900 lbs.	16mm	17.9 Kg	5.9 MT	6.5 MT
3/4"	2-1/4"	15.0 lbs.	16,000 lbs.	18mm	22.3 Kg	7.3 MT	8.1 MT
7/8"	2-3/4"	22.0 lbs.	24,700 lbs.	22mm	32.7 Kg	11.2 MT	12.4 MT
1"	3"	26.0 lbs.	30,600 lbs.	24mm	38.7 Kg	13.9 MT	15.4 MT
1-1/8"	3-1/2"	36.0 lbs.	38,300 lbs.	28mm	53.6 Kg	17.4 MT	19.3 MT
1-1/4"	3-3/4"	41.0 lbs.	44,200 lbs.	30mm	61.0 Kg	20.0 MT	22.3 MT
1-5/16"	4"	43.5 lbs.	50,200 lbs.	32mm	64.7 Kg	22.8 MT	25.3 MT
1-1/2"	4-1/2"	60.0 lbs.	62,900 lbs.	36mm	89.3 Kg	28.5 MT	31.7 MT
1-5/8"	5"	74.0 lbs.	77,400 lbs.	40mm	110.1 Kg	35.1 MT	39.0 MT
1-3/4"	5-1/2"	89.0 lbs.	93,500 lbs.	44mm	132.4 Kg	42.4 MT	47.1 MT
2"	6"	106.0 lbs.	111,400 lbs.	48mm	157.7 Kg	50.5 MT	56.1 MT
2-1/8"	6-1/2"	124.0 lbs.	130,100 lbs.	52mm	184.5 Kg	59.0 MT	65.6 MT
2-1/4"	7"	144.0 lbs.	150,500 lbs.	56mm	214.3 Kg	68.3 MT	75.9 MT
2-1/2"	7-1/2"	165.0 lbs.	171,700 lbs.	60mm	245.6 Kg	77.9 MT	86.5 MT
2-5/8"	8"	188.0 lbs.	195,500 lbs.	64mm	279.8 Kg	88.7 MT	98.5 MT
2-3/4"	8-1/2"	212.0 lbs.	218,500 lbs.	68mm	315.5 Kg	99.1 MT	110.1 MT
3"	9"	238.0 lbs.	242,300 lbs.	72mm	354.2 Kg	109.9 MT	122.1 MT
3-1/4"	10"	294.0 lbs.	273,700 lbs.	80mm	437.5 Kg	124.2 MT	137.9 MT
3-5/8"	11"	356.0 lbs.	326,400 lbs.	88mm	529.8 Kg	148.1 MT	164.5 MT
4"	12"	423.0 lbs.	383,400 lbs.	96mm	629.5 Kg	173.9 MT	193.2 MT
4-1/4"	13"	497.0 lbs.	444,600 lbs.	104mm	739.6 Kg	201.7 MT	224.1 MT
4-5/8"	14"	576.0 lbs.	509,200 lbs.	112mm	857.2 Kg	231.0 MT	256.6 MT
5"	15"	662.0 lbs.	578,000 lbs.	120mm	985.2 Kg	262.2 MT	291.3 MT

2-IN-1 SUPER STRONG™



8-STRAND SSR-I200: A BLENDED 8-STRAND WITH THE WEAR RESISTANCE AND STRENGTH OF AN ALL POLYESTER ROPE BUT SIGNIFICANTLY LESS HANDLING WEIGHT.

FEATURES:

- 20% less weight than an all Polyester constructions
- Excellent strength with low working elongation
- Non rotational—Non Hockling
- Excellent wear and flexibility

APPLICATIONS:

- Secondary Mooring Lines
- Tug Assist lines for use with H-bitts
- Barge tie-up lines

SSR-1200™ is a non-rotational rope with an excellent coefficient of friction for working off H-bitts for Tug Assist Lines on conventional tugs or tractor tugs without winch drums. To minimize connection weight to the assisted ship, many operators use an AmSteel-Blue connection pendant for their light weight and high wear resistance.



8-STRAND

Size Dia. Inches	Size Circ. Inches	Weight lbs. Per 100 FT.	SRT MBS/lbs.	Size Dia. mm	Weight KG Per 100 M	SRT MBS/Metric Tonnes	ISO/BS EN919 Strength/Metric Tonnes
1-5/8"	5"	68.0 lbs.	61,200 lbs.	40mm	101.2 Kg	27.8 MT	30.8 MT
1-3/4"	5-1/2"	78.4 lbs.	71,100 lbs.	44mm	116.7 Kg	32.3 MT	35.8 MT
2"	6"	99.0 lbs.	89,100 lbs.	48mm	147.3 Kg	40.4 MT	44.9 MT
2-1/8"	6-1/2"	111.3 lbs.	99,000 lbs.	52mm	165.6 Kg	44.9 MT	49.9 MT
2-1/4"	7"	128.9 lbs.	113,000 lbs.	56mm	191.8 Kg	51.3 MT	57.0 MT
2-1/2"	7-1/2"	155.7 lbs.	135,000 lbs.	60mm	231.7 Kg	61.2 MT	68.0 MT
2-5/8"	8"	170.1 lbs.	148,000 lbs.	64mm	253.1 Kg	67.1 MT	74.6 MT
3"	9"	220.6 lbs.	191,000 lbs.	72mm	328.3 Kg	86.6 MT	96.3 MT
3-1/4"	10"	262.9 lbs.	227,000 lbs.	80mm	391.2 Kg	103.0 MT	114.4 MT
3-5/8"	11"	326.8 lbs.	281,000 lbs.	88mm	486.3 Kg	127.5 MT	141.6 MT
4"	12"	396.9 lbs.	337,000 lbs.	96mm	590.7 Kg	152.9 MT	169.8 MT

8-STRAND SSR-I200

PRODUCT CODE: 263

TECHNICAL SPECIFICATIONS:

CLASS I ROPE

SPECIFIC GRAVITY:

1.20

ELASTIC ELONGATION PERCENTAGE:

At % of break strength

10% 1.4%

20% 2.8%

30% 3.4%

SPlicing PROCEDURES REQUIRED:

- EYE SPLICE –
8-Strand/Class I Rope
- END FOR END SPLICE –
8-Strand/Class I Rope

SAMSON



3-STRAND



3-STRAND SSR-I200: A BLENDED ROPE WITH THE WEAR RESISTANCE AND STRENGTH OF AN ALL POLYESTER ROPE BUT SIGNIFICANTLY LESS HANDLING WEIGHT.

FEATURES:

- Equal strength and wear of an all Polyester rope
- 20% less weight than an all Polyester rope
- Low working elongation
- Excellent grip on H-bitts

APPLICATIONS:

- Barge/dredge working lines
- Tug Assist Lines
- Tie-up lines
- Deck/handy lines

3-strand SSR-1200™ will provide lower operating costs by providing longer service life than conventional blended fiber ropes. This is accomplished through a unique plied yarn construction using a combination of polyester fiber and our proprietary Ultra Blue bi-polymer fiber in each yarn of the strand formation. The combination minimizes the amount of polyester fiber and relies on the light-weight, non water absorbing features of the Ultra Blue fiber.

3-STRAND SSR-I200

PRODUCT CODE: 220

TECHNICAL SPECIFICATIONS:

CLASS I ROPE

Available in sizes 1/4" – 3-1/4" dia.

SPECIFIC GRAVITY:

1.20

ELASTIC ELONGATION PERCENTAGE:

At % of break strength

10% 1.5%

20% 3.2%

30% 4.0%

SPlicing PROCEDURES REQUIRED:

- EYE SPLICE –
3-Strand/Class I Rope
- END FOR END SPLICE –
3-Strand/Class I Rope

Size Dia. Inches	Size Circ. Inches	Weight lbs. Per 100 FT.	SRT MBS/lbs.	Size Dia. mm	Weight KG Per 100 M	SRT MBS/Metric Tonnes	ISO/BS EN919 Strength/Metric Tonnes
1"	3"	25.6 lbs.	22,900 lbs.	24mm	38.1 Kg	10.4 MT	11.5 MT
1-1/8"	3-1/2"	33.0 lbs.	29,500 lbs.	28mm	49.1 Kg	13.4 MT	14.9 MT
1-1/4"	3-3/4"	39.4 lbs.	35,100 lbs.	30mm	58.6 Kg	15.9 MT	17.7 MT
1-5/16"	4"	43.3 lbs.	38,700 lbs.	32mm	64.4 Kg	17.6 MT	19.5 MT
1-1/2"	4-1/2"	56.2 lbs.	48,600 lbs.	36mm	83.6 Kg	22.0 MT	24.5 MT
1-5/8"	5"	68.0 lbs.	58,500 lbs.	40mm	101.2 Kg	26.5 MT	29.5 MT
1-3/4"	5-1/2"	78.4 lbs.	67,500 lbs.	44mm	116.7 Kg	30.6 MT	34.0 MT
2"	6"	99.0 lbs.	84,600 lbs.	48mm	147.3 Kg	38.4 MT	42.6 MT
2-1/8"	6-1/2"	111.3 lbs.	94,500 lbs.	52mm	165.8 Kg	42.9 MT	47.6 MT
2-1/4"	7"	128.9 lbs.	108,000 lbs.	56mm	191.8 Kg	49.0 MT	54.4 MT
2-1/2"	7-1/2"	155.7 lbs.	128,000 lbs.	60mm	231.7 Kg	58.1 MT	64.5 MT
2-5/8"	8"	170.1 lbs.	140,000 lbs.	64mm	253.1 Kg	63.5 MT	70.6 MT
3"	9"	220.6 lbs.	182,000 lbs.	72mm	328.3 Kg	82.6 MT	91.7 MT

3-STRAND SSR-I200™



8-STRAND

8-STRAND ULTRA-BLUE: HIGHER STRENGTH AND MORE THAN DOUBLE THE WEAR LIFE OF STANDARD 8-STRAND POLYPROPYLENE.

FEATURES:

- Superior strength to standard 8-strand Polypropylene ropes
- Over twice the wear life of standard 8-strand Polypropylene ropes
- Floating non rotational flexible construction
- Excellent Flex wear resistance

APPLICATIONS:

- Secondary Mooring Lines
- Barge/dredge working line
- Trailer tow lines
- Messenger & pick-up lines

The Ultra Blue fiber enhances the grip by developing a distinct outer surface fuzz that acts as a wear protector for the subsurface fibers. Ultra Blue fiber also has better UV properties than conventional olefin fibers.

TECHNICAL SPECIFICATIONS:

CLASS I ROPE

Available in sizes 1" – 4" diameter

SPECIFIC GRAVITY: .94

ELASTIC ELONGATION PERCENTAGE:

- At % of break strength
- 10% 1.7%
- 20% 3.5%
- 30% 4.2%

SPLICING PROCEDURES REQUIRED:

- EYE SPLICE – 8-Strand/Class I Rope
- END FOR END SPLICE – 8-Strand/Class I Rope

Size Dia. Inches	Size Circ. Inches	Weight lbs. Per 100 FT.	SRT MBS/lbs.	Size Dia. mm	Weight KG Per 100 M	SRT MBS/Metric Tonnes	ISO/BS EN919 Strength/Metric Tonnes
1-5/8"	5"	51.0 lbs.	52,200 lbs.	40mm	75.9 Kg	23.7 MT	26.3 MT
1-3/4"	5-1/2"	60.0 lbs.	62,100 lbs.	44mm	89.3 Kg	28.2 MT	31.3 MT
2"	6"	71.0 lbs.	73,800 lbs.	48mm	105.7 Kg	33.5 MT	37.2 MT
2-1/8"	6-1/2"	84.0 lbs.	81,000 lbs.	52mm	125.0 Kg	36.7 MT	40.8 MT
2-1/4"	7"	98.0 lbs.	98,100 lbs.	56mm	145.8 Kg	44.5 MT	49.4 MT
2-1/2"	7-1/2"	112.0 lbs.	113,000 lbs.	60mm	166.7 Kg	51.3 MT	57.0 MT
2-5/8"	8"	127.0 lbs.	126,000 lbs.	64mm	189.0 Kg	57.2 MT	63.5 MT
2-3/4"	8-1/2"	145.0 lbs.	142,000 lbs.	68mm	215.8 Kg	64.4 MT	71.6 MT
3"	9"	163.0 lbs.	158,000 lbs.	72mm	242.6 Kg	71.7 MT	79.6 MT
3-1/4"	10"	202.0 lbs.	194,000 lbs.	80mm	300.6 Kg	88.0 MT	97.8 MT
3-5/8"	11"	242.0 lbs.	231,000 lbs.	88mm	360.1 Kg	104.8 MT	116.4 MT
4"	12"	285.0 lbs.	275,000 lbs.	96mm	424.1 Kg	124.7 MT	138.6 MT

3-STRAND ULTRA BLUE: HIGHER STRENGTH, BETTER GRIP, AND LONGER SERVICE LIFE THAN STANDARD POLYPROPYLENE ROPES.

FEATURES:

- Floating high strength bi-polymer rope
- Over twice the wear life of polypropylene
- Superior UV resistance to polypropylene

APPLICATIONS:

- Tie-up lines
- Floating trailer tow lines
- General deck and handlines

The Ultra Blue fiber enhances the gripping capability by developing a distinct initial outer surface fuzz that also acts as a wear protector for the subsurface fibers. Its strength and wear features allow downsizing to reduce handling weight and improve efficiency. Potential rope related injuries during rope deployment or retrieval are minimized.



3-STRAND

TECHNICAL SPECIFICATIONS:

CLASS I ROPE

Available in sizes 1/4" – 3-1/4" dia.

SPECIFIC GRAVITY: .94

ELASTIC ELONGATION PERCENTAGE:

- At % of break strength
- 10% 2.0%
- 20% 4.8%
- 30% 6.8%

SPLICING PROCEDURES REQUIRED:

- EYE SPLICE – 3-Strand/Class I Rope
- END FOR END SPLICE – 3-Strand/Class I Rope

Size Dia. Inches	Size Circ. Inches	Weight lbs. Per 100 FT.	SRT MBS/lbs.	Size Dia. mm	Weight KG Per 100 M	SRT MBS/Metric Tonnes	ISO/BS EN919 Strength/Metric Tonnes
1"	3"	18.6 lbs.	20,300 lbs.	24mm	27.7 Kg	9.2 MT	10.2 MT
1-1/8"	3-1/2"	24.7 lbs.	23,900 lbs.	28mm	36.8 Kg	10.8 MT	12.0 MT
1-1/4"	3-3/4"	28.9 lbs.	29,700 lbs.	30mm	43.0 Kg	13.5 MT	15.0 MT
1-5/16"	4"	32.5 lbs.	33,300 lbs.	32mm	48.4 Kg	15.1 MT	16.8 MT
1-1/2"	4-1/2"	41.2 lbs.	37,800 lbs.	36mm	61.3 Kg	17.1 MT	19.1 MT
1-5/8"	5"	52.6 lbs.	49,500 lbs.	40mm	78.3 Kg	22.5 MT	24.9 MT
1-3/4"	5-1/2"	61.9 lbs.	58,500 lbs.	44mm	92.1 Kg	26.5 MT	29.5 MT
2"	6"	73.2 lbs.	70,200 lbs.	48mm	108.9 Kg	31.8 MT	35.4 MT
2-1/4"	7"	101.0 lbs.	92,700 lbs.	56mm	150.3 Kg	42.0 MT	46.7 MT
2-1/2"	7-1/2"	115.5 lbs.	106,000 lbs.	60mm	171.9 Kg	48.1 MT	53.4 MT
2-5/8"	8"	130.9 lbs.	120,000 lbs.	64mm	194.8 Kg	54.4 MT	60.5 MT
3"	9"	168.0 lbs.	150,000 lbs.	72mm	250.0 Kg	68.0 MT	75.6 MT

8-STRD ULTRA BLUE™

3-STRD ULTRA BLUE™

PRODUCT CODE: 256



8-STRAND

8-STRAND PRO-SET NYLON: 100% NYLON 8-STRAND, WITH FULL LIFE FLEXIBILITY FOR EASE OF HANDLING AND SPLICING AND EXCELLENT SHOCK MITIGATION.

FEATURES:

- High energy absorption
- Superior long term wet wear
- Non rotational balanced construction

APPLICATIONS:

- Tow/shock lines
- Mooring lines
- SBM lines
- Emergency tow lines

Pro-Set Nylon™ uses only quality 100% nylon fibers that insure proper twist and lay tension and to eliminate shrink hardening during use. The finished 4-stage construction rope stays flexible with firm strand formation to maximize resistance to wear and minimize snagging during its service life.

TECHNICAL SPECIFICATIONS:

CLASS I ROPE

SPECIFIC GRAVITY: 1.14

ELASTIC ELONGATION PERCENTAGE:

- At % of break strength
- 10% 5.0%
- 20% 10.2%
- 30% 12.0%

SPLICING PROCEDURES REQUIRED:

- EYE SPLICE – 8-Strand/Class I Rope
- END FOR END SPLICE – 8-Strand/Class I Rope

Size Dia. Inches	Size Circ. Inches	Weight lbs. Per 100 FT.	SRT MBS/lbs.	Size Dia. mm	Weight KG Per 100 M	SRT MBS/Metric Tonnes	ISO/BS EN919 Strength/Metric Tonnes
1-5/8"	5"	69.3 lbs.	68,000 lbs.	40mm	103.1 Kg	30.8 MT	34.3 MT
1-3/4"	5-1/2"	86.5 lbs.	84,000 lbs.	44mm	128.7 Kg	38.1 MT	42.3 MT
2"	6"	99.0 lbs.	96,000 lbs.	48mm	147.3 Kg	43.5 MT	48.4 MT
2-1/8"	6-1/2"	113.5 lbs.	109,000 lbs.	52mm	168.9 Kg	49.4 MT	54.9 MT
2-1/4"	7"	134.4 lbs.	130,000 lbs.	56mm	200.0 Kg	59.0 MT	65.5 MT
2-1/2"	7-1/2"	155.2 lbs.	146,000 lbs.	60mm	231.0 Kg	66.2 MT	73.6 MT
2-5/8"	8"	175.0 lbs.	165,000 lbs.	64mm	260.4 Kg	74.8 MT	83.2 MT
2-3/4"	8-1/2"	196.9 lbs.	186,000 lbs.	68mm	293.0 Kg	84.4 MT	93.7 MT
3"	9"	218.8 lbs.	205,000 lbs.	72mm	325.6 Kg	93.0 MT	103.3 MT
3-1/4"	10"	275.0 lbs.	258,000 lbs.	80mm	409.3 Kg	117.0 MT	130.0 MT
3-5/8"	11"	325.0 lbs.	304,000 lbs.	88mm	483.7 Kg	137.9 MT	153.2 MT
4"	12"	395.8 lbs.	365,000 lbs.	96mm	589.0 Kg	165.6 MT	184.0 MT
4-1/4"	13"	463.5 lbs.	430,000 lbs.	104mm	689.0 Kg	195.0 MT	216.7 MT
4-5/8"	14"	541.7 lbs.	508,000 lbs.	112mm	806.2 Kg	230.4 MT	256.0 MT
5"	15"	614.6 lbs.	575,000 lbs.	120mm	914.6 Kg	260.8 MT	289.8 MT
5-1/4"	16"	703.1 lbs.	645,000 lbs.	128mm	1046.4 Kg	292.6 MT	325.1 MT
5-1/2"	17"	796.9 lbs.	698,000 lbs.	136mm	1185.9 Kg	316.6 MT	351.8 MT
6"	18"	895.8 lbs.	798,000 lbs.	144mm	1331.1 Kg	362.0 MT	402.2 MT



3-STRAND

PRODUCT CODE: 170

3-STRAND PRO-SET NYLON: A PREMIUM FOUR STAGE 100% NYLON ROPE.

FEATURES:

- Good UV resistance and wet abrasion resistance
- High elasticity with excellent shock mitigation
- Balanced construction resists hockling
- Smooth consistent strand formation for maximum wear life

APPLICATIONS:

- Tie-up & mooring lines
- Shock & tow lines
- Anchor lines
- Deck lines

100% nylon fiber marine ropes which do not use substandard components provide longer service life with certified strength. Pro-Set Nylon is a four-stage rope that allows full life flexibility for ease of handling and splicing.

TECHNICAL SPECIFICATIONS:

CLASS I ROPE

Available in sizes 1/4" – 3-1/4" dia.

SPECIFIC GRAVITY: 1.14

ELASTIC ELONGATION PERCENTAGE:

- At % of break strength
- 10% 5.5%
- 20% 10.0%
- 30% 12.1%

SPLICING PROCEDURES REQUIRED:

- EYE SPLICE & END FOR END SPLICE – 3-Strand/Class I Rope

Size Dia. Inches	Size Circ. Inches	Weight lbs. Per 100 FT.	SRT MBS/lbs.	Size Dia. mm	Weight KG Per 100 M	SRT MBS/Metric Tonnes	ISO/BS EN919 Strength/Metric Tonnes
1"	3"	26.0 lbs.	25,000 lbs.	24mm	38.7 Kg	11.3 MT	12.6 MT
1-1/16"	3-1/4"	29.0 lbs.	27,200 lbs.	26mm	43.2 Kg	12.3 MT	13.7 MT
1-1/8"	3-1/2"	34.0 lbs.	32,000 lbs.	28mm	50.6 Kg	14.5 MT	16.1 MT
1-1/4"	3-3/4"	40.0 lbs.	37,500 lbs.	30mm	59.5 Kg	17.0 MT	18.9 MT
1-5/16"	4"	45.0 lbs.	41,500 lbs.	32mm	67.0 Kg	18.8 MT	20.9 MT
1-1/2"	4-1/2"	55.0 lbs.	52,000 lbs.	36mm	81.9 Kg	23.6 MT	26.2 MT
1-5/8"	5"	66.5 lbs.	63,000 lbs.	40mm	99.0 Kg	28.6 MT	31.8 MT
1-3/4"	5-1/2"	83.0 lbs.	78,000 lbs.	44mm	123.5 Kg	35.4 MT	39.3 MT
2"	6"	95.0 lbs.	89,000 lbs.	48mm	141.4 Kg	40.4 MT	44.9 MT
2-1/8"	6-1/2"	109.0 lbs.	101,000 lbs.	52mm	162.2 Kg	45.8 MT	50.9 MT
2-1/4"	7"	129.0 lbs.	121,000 lbs.	56mm	192.0 Kg	54.9 MT	61.0 MT
2-1/2"	7-1/2"	149.0 lbs.	135,000 lbs.	60mm	221.7 Kg	61.2 MT	68.0 MT
2-5/8"	8"	168.0 lbs.	153,000 lbs.	64mm	250.0 Kg	69.4 MT	77.1 MT
2-3/4"	8-1/2"	189.0 lbs.	173,000 lbs.	68mm	281.3 Kg	78.5 MT	87.2 MT
3"	9"	210.0 lbs.	190,000 lbs.	72mm	312.5 Kg	86.2 MT	95.8 MT

8-STRD PRO-SET NYLON™

3-STRD PRO-SET NYLON™



3-STRAND SSR-301R: THE BEST INLAND WATERWAYS LOCKLINE AVAILABLE - A SMOOTH CHECKING LINE WITH TWICE THE WEAR LIFE OF STANDARD LOCKLINE CONSTRUCTIONS.

FEATURES:

- Most cost effective Lockline available
- Gives long term smooth consistent checking
- Low working elongation for control
- Excellent flex and wear resistance

APPLICATIONS:

- Locklines
- Barge/tug mooring lines

The SSR-301R™ construction is the most long-term cost effective Lockline available. It is a light weight, high strength, and consistently-smooth checking line with twice the wear life of standard Lockline constructions.

Three proprietary components are combined in SSR-301R: Resistex lubricant is applied to the internal strand core yarns and migrates outwardly under load to lubricate the surface yarns; Bi-polymer olefin fiber maximizes the weight to strength ratio; and integrated external yarn construction of spun and filament polyester fiber. All three components work together to create a light weight, highly heat resistant, consistently reliable Lockline with a long service life.



3-STRAND

Size Dia. Inches	Size Circ. Inches	Weight lbs. Per 100 FT.	SRT MBS/lbs.	Size Dia. mm	Weight KG Per 100 M	SRT MBS/Metric Tonnes	ISO/BS EN919 Strength/Metric Tonnes
1-5/8"	5"	57.5 lbs.	46,800 lbs.	40mm	85.6 Kg	21.2 MT	23.6 MT
1-3/4"	5-1/2"	66.0 lbs.	55,500 lbs.	44mm	98.2 Kg	25.2 MT	28.0 MT
2"	6"	82.0 lbs.	64,000 lbs.	48mm	122.0 Kg	29.0 MT	32.3 MT

SSR-301R

PRODUCT CODE: 226

TECHNICAL SPECIFICATIONS:

CLASS I ROPE

SPECIFIC GRAVITY:

1.14

ELASTIC ELONGATION PERCENTAGE:

At % of break strength

10% 2.1%

20% 3.5%

30% 4.0%

SPLICING PROCEDURES REQUIRED:

- EYE SPLICE –
3-Strand/Class I Rope
- END FOR END SPLICE –
3-Strand/Class I Rope

ROPE SPLICING

FOR SPLICING BRAIDED ROPE CONSTRUCTIONS, FIDS ARE UTILIZED TO PERFORM THE APPROPRIATE SPLICE PROCEDURE BASED ON THE CLASS AND TYPE OF BRAID CONSTRUCTION.

The fids are used in making required measurements and in burying the rope during the splicing operation. Each diameter of rope has a matching fid size and to insure that the required measurements are made correctly, the proper sized fid for the rope size must be used in performing a splice. There are two styles of fids offered: Aluminum Tubular Fids and Wire Fids. The Aluminum Tubular Fids are used by inserting the end rope section into the fid while the Wire Fids are attached to the end of the rope section. Tubular Fids are pushed through the rope with an appropriate sized pusher where Wire Fids are either fed through the rope or pulled through by attaching a feed line.

TUBULAR FID & PUSHER



Product Code	Dimensions Fid size & Rope Dia.	Total Fid Length	Short Fid Section Length	Pusher	Product Code
901	1/4"	5-1/2"	2-1/16"	Small	913
901	5/16"	6-3/4"	2-1/2"	Small	913
901	3/8"	7-3/4"	2-7/8"	Small	913
901	7/16"	9-1/2"	3-9/16"	Small	913
901	1/2"	11"	4-1/8"	Small	913
901	9/16"	12-1/4"	3-5/8"	Large	914
901	5/8"	14"	4-1/8"	Large	914
901	3/4"	16"	4-3/4"	Large	914
901	7/8"	19"	4-3/4"	Large	914
901	1"	21"	5-1/4"	Large	914



WIRE FID



Product Code	Fid size & Rope Dia.	Total Fid Length	Short Fid Section Length
905	1-1/8"	12-1/4"	3"
905	1-1/4"	13-1/4"	3-1/4"
905	1-15/16"	14"	3-1/2"
905	1-1/2"	16"	4"
905	1-5/8"	17-1/2"	4-1/2"
905	1-3/4"	19"	4-3/4"
905	2"	21"	5-1/4"
905	2-1/8"	23"	5-3/4"
905	2-1/4"	25"	6"
905	2-1/2"	26"	6-1/2"
905	2-5/8"	28"	7"
905	2-3/4"	30"	7-1/2"
905	3"	32"	8"
905	3-1/4"	35"	8-3/4"

*Dimensions and Lengths are to 1/2 scale

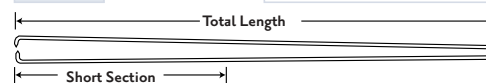

SPLICING INSTRUCTIONS:

THE MOST CURRENT AND UP-TO-DATE SPLICING INSTRUCTIONS FOR PRODUCTS LISTED IN THE CATALOG ARE AVAILABLE ONLINE AT:

www.samsonrope.com.

As depicted in the catalog, our rope constructions are stated as Class I and Class II ropes (see glossary of terms) and each type of rope class requires unique splicing procedures:

CLASS I ROPE SPLICING INSTRUCTIONS

- | | |
|--------------------------------|--|
| Eye Splice – 12-Strand Rope | End for End Splice – 12-Strand Rope |
| Eye Splice – Round Plait Rope | End for End Splice – Round Plait Rope |
| Eye Splice – Double Braid Rope | End for End Splice – Double Braid Rope |
| Eye Splice – 3-Strand Rope | End for End Splice – 3-Strand Rope |
| Eye Splice – 8-Strand Rope | End for End Splice – 8-Strand Rope |

CLASS II ROPE SPLICING INSTRUCTIONS

- | | |
|--------------------------------|--|
| Eye Splice – 12-Strand Rope | End for End Splice – 12-Strand Rope |
| Eye Splice – Round Plait Rope | End for End Splice – Round Plait Rope |
| Eye Splice – Double Braid Rope | End for End Splice – Double Braid Rope |
| Eye Splice – 8-Strand Rope | End for End Splice – 8-Strand Rope |
| Eye Splice – 8x3-Strand Rope | End for End Splice – 8x3-Strand Rope |

SPLICING KITS:

The Samson Splice Training Kit comes complete with a fid, pusher, instruction manual and two lengths of double braided ropes.



The Samson Splicing Kit comes with 5 aluminum tubular fids (size range 1/4" through 1/2" diameter)

Requirements for design, engineering, and fabrication production of single ropes or complex ropes systems can be directed to the Applications Engineering Group at: Samson Rope Technologies, 2090 Thornton Street, Ferndale, WA 98248

ROPE HARDWARE: THIMBLES

NYLITE™

PRODUCT CODE: 964

SPOOLS, SHEILDS AND SHACKLE ASSEMBLY

Unlike conventional thimbles the Nylite Connector Assembly is easily installed into or removed from a pre-made soft eye. Only one-seventh the weight of metal thimbles, Nylite connectors will not deform or rupture from repeated loadings. The Nylite Shackle was designed to take full advantage of the high strength of the Nylite connector and synthetic rope.



WORKING DETAILS:

- Working Load in tons (2000 lbs.)
- Working loads, as given, are based on pin/bore relationship provided by use of Nylite Shackle. When using a non-standard pin, the Working Load as given DOES NOT APPLY.
- When using with Class II ropes, upsize to ensure working load compatibility.

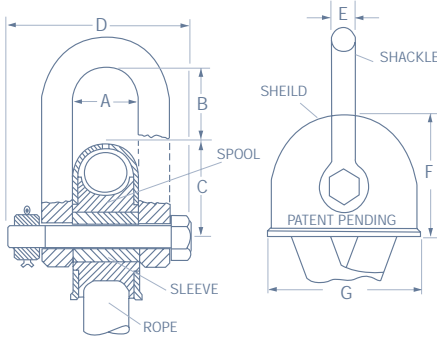

*The Nylite Spool and Shield in sizes 1-5 may be purchased without a shackle (part # 969). Minimum order quantities apply, see net price list for details.

*The Nylite Shackle sizes 1-9 may be purchased separately (part # 961).

Size	Size Daimeter	Size Circ.	SRT Minimum Eye size	Working Load Tons	Weight Each (Lbs.)	Shield Color
-1	3/8" - 1/2"	1-1/8" - 1-1/2"	2-3/16"	1.1 tn	0.5 lbs.	Blue
-2	9/16" - 5/8"	1-3/4" - 2"	2-3/4"	1.6 tn	1.0 lbs.	Red
-3	3/4" - 13/16"	2-1/4" - 2-1/2"	3-3/4"	2.5 tn	1.6 lbs.	Green
-4	7/8" - 1-1/16"	2-3/4" - 3-1/4"	4-7/8"	4.5 tn	3.7 lbs.	Orange
-5	1-1/8" - 1-5/16"	3-1/2" - 4"	6-1/8"	7.5 tn	6.0 lbs.	Black
-6	1-1/2" - 1-3/4"	4-1/2" - 5-1/2"	7-5/8"	12.5 tn	19.0 lbs.	Yellow
-7	2" - 2-1/4"	6" - 7"	9-3/4"	20.0 tn	24.0 lbs.	Black
-8	2-1/2" - 2-5/8"	7-1/2" - 8"	11-1/4"	25.0 tn	33.0 lbs.	Black
-9	2-3/4" - 3-1/4"	8-1/2" - 10"	14"	35.0 tn	56.0 lbs.	Black

Size	Spool/Sheave Inside Dia.	Spool Sheave Outside Dia.	Pin* Dia.	A	B	C	D	E	F	G
-1	.46"	N/A	.44"	.88"	1.08"	1.11"	2.41"	.38"	1.99"	2.34"
-2	.58"	N/A	.56"	1.13"	1.21"	1.38"	3.11"	.50"	2.38"	2.88"
-3	.64"	N/A	.63"	1.38"	1.61"	1.77"	3.54"	.56"	3.02"	3.70"
-4	.89"	N/A	.88"	1.75"	1.9"	2.29"	4.70"	.75"	3.79"	4.71"
-5	1.02"	N/A	1.00"	2.13"	2.15"	2.85"	5.55"	.88"	4.85"	5.95"
-6	1.54"	N/A	1.50"	2.63"	3.14"	3.8"	8.25"	1.37"	6.30"	7.85"
-7	1.75"	3.00"	1.38"	3.25"	3.75"	4.80"	8.90"	1.50"	7.93"	9.89"
-8	2.00"	3.25"	1.50"	3.75"	4.13"	5.61"	10.00"	1.75"	9.24"	11.47"
-9	2.25"	3.50"	1.75"	4.63"	5.06"	6.95"	12.15"	2.00"	11.45"	14.28"

*Sizes 1 - 5 are supplied with jam nuts and cotter pins. Larger sizes have cotter pins and standard nuts.

BLUE LINE THIMBLE

PRODUCT CODE: 930

The Blue Line thimble is compatible for use with Samson's high performance - high modulus synthetic fiber rope products such as AmSteel-Blue, Force-8, and DPX 75. The tubular gusseted design creates a high strength thimble that protects the rope and maintains a proper bending radius when connected to mating hardware.

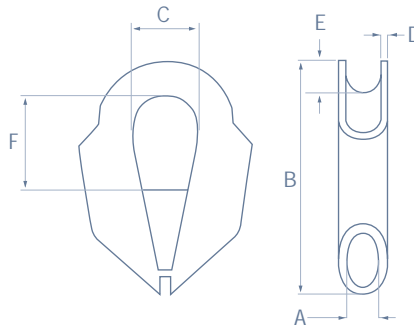

Size Range Dia. Inches	Thimble Weight Lbs.	A Inches	B Inches	C Inches	D Inches	E Inches	F Inches	Size Range Dia. MM	A MM	B MM	C MM	D MM	E MM	F MM
3-16" - 3/8"	0.6	.427	3.74	.906	.157	.315	1.89	5mm - 9mm	12	95	23	4.0	8	48
7/16" - 1/2"	1.0	.591	4.29	1.06	.197	.394	1.93	11mm - 16mm	19	125	32	5.0	12	49
9/16" - 5/8"	1.5	.748	4.92	1.26	.197	.472	1.69	14mm - 16mm	19	125	32	5.0	12	43
3/4" - 7/8"	3.0	.984	6.22	1.77	.248	.630	2.32	18mm - 22mm	25	158	45	6.3	16	59
1" - 1-1/8"	6.0	1.38	8.27	2.36	.276	.866	3.66	24mm - 28mm	35	210	60	7.0	22	93
1-1/4" - 1-1/2"	8.0	1.77	9.96	2.76	.276	1.06	3.70	30mm - 36mm	45	253	70	7.0	27	94
1-5/8"	9.3	1.97	11.02	2.95	.276	1.10	3.78	40mm	50	280	75	7.0	28	96

ROPE HARDWARE: THIMBLES & CHAFE PROTECTION



The cast steel extra heavy duty hawser thimble is designed for use with wire rope or high performance synthetic fiber ropes such as Amsteel Blue, Force 8, & DPX 75. The galvanized thimble provides smooth even grooves, maximum strengths at critical areas, and proper bending radius for the rope. When used with synthetic ropes, thimble eye should be lashed at approximately 2, 4, 8, & 10 o'clock on the thimble circumference to secure the thimble to the rope when not in service.

HEAVY DUTY HAWSER THIMBLE

PRODUCT CODE: 933

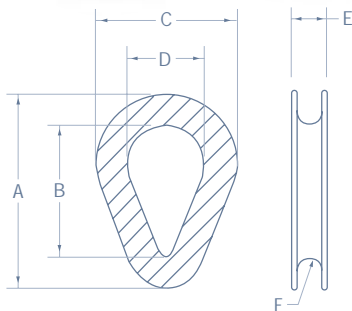

Size Range Dia. Inches	Size Range Dia. MM	Dimensions in Inches						Unit Weight Lbs.
		A	B	C	D	E	F	
5/8" - 3/4"	16 - 18	6.875	4.5	5.0	3.0	1.1875	.40625	3.5
7/8" - 1"	22 - 24	8.625	5.75	6.25	3.75	1.4375	.53125	6.0
1-1/8" - 1-1/4"	28 - 30	10.125	6.75	6.25	3.75	1.6875	.65625	9.5
1-3/8" - 1-1/2"	32 - 36	12.125	8.0	8.75	5.0	2.1875	.78125	18.5
1-5/8" - 1-3/4"	40 - 44	12.75	8.0	9.25	5.0	2.4375	.9375	24.0
1-7/8" - 2"	45 - 48	14.75	9.5	10.75	6.0	2.6875	1.0625	33.5
2-1/8" - 2-1/4"	52 - 56	17.125	11.0	12.5	7.0	3.125	1.1875	53.5
2-3/8" - 2-1/2"	57 - 60	19.25	12.75	14.25	8.25	3.875	1.375	81.5
2-3/4" - 3"	68 - 72	24.5	15.0	17.0	9.375	4.9375	1.625	136.5
3-1/4" - 3-1/2"	80 - 84	30.0	19.5	20.0	11.5	5.5	1.875	216.5

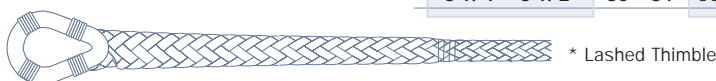

Chafe-Gard protects your synthetic mooring lines from chock wear which adds service life performance and reliability. These benefits are due to the unique design of a tubular braided polyester structure that is externally coated with a highly wear resistant rubberized compound. Mooring lines are allowed to adjust under tension on the inner polyester braided liner and the rubberized outer covering minimizes the overall Chafe-Gard movement in the chock based on its high frictional characteristics. Each end of the Chafe-Gard unit has sets of grommets for the attachment of control lines for tying off to deck or bulwark cleats.

CHAFE-GARD

PRODUCT CODE: 999

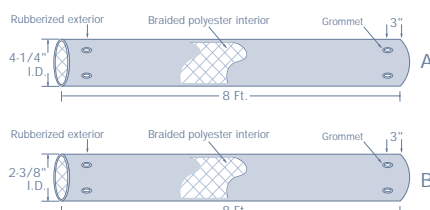

Mooring Line Application	Model Type	Rope Dia. Size Range	SRT Part #	Avg. Unit Weight Lbs.
Primary Mooring Lines	A	1-1/8" - 2"	999 601 100 019	2.8
Secondary Mooring Lines	B	2" - 3"	999 601 200 019	5.2



EXTEND YOUR ROPE'S SERVICE LIFE BY PROTECTING IT WITH THE MOST CUT AND WEAR RESISTANT MATERIAL AVAILABLE.

Pro-Gard Eye and Rope Protectors are constructed of dual woven fabric layers of treated HMPE fiber materials. The finer inner fabric layer allows the rope to adjust to load while the thick outer wear fabric layer has a high coefficient of friction treatment to minimize movement on the contact surface. Both the eye and rope protectors are easily installed in the field on functioning ropes due to the unique attachment/closure system. The protectors are flexible, light weight, don't absorb water and float.

Rope Diameter Range (Inches)	Model Reference
1/2" - 5/8"	A
3/4" - 1"	B
1-1/8" - 1-3/4"	C
1-7/8" - 2-1/2"	D
2-5/8" - 3-1/4"	E

WORKING DETAILS:

- Grommets installed for ease of securement
- Eye protector gusseted for custom fit
- Eye protectors sold in five standard leg lengths for all models: 20", 30", 40" 50", & 60"
- Rope protectors sold in standard 10 Ft. (3 Meter) lengths

PRO-GARD EYE & ROPE PROTECTOR

PRODUCT CODE: 973 (Eye Protector)



Pro-Gard Rope Protector also available for mooring lines.

PRODUCT CODE: 974 (Rope Protector)

SAMTHANE COATING

SAMTHANE™

SAMTHANE COATINGS ARE A FAMILY OF ABRASION RESISTANT COATINGS SPECIFICALLY FORMULATED TO MATCH END-USER REQUIREMENTS AND SPECIFIC ROPE CONSTRUCTIONS. THE ADVANTAGES AND DIFFERENCES OF THESE COATINGS ARE OUTLINED BELOW.

SAMTHANE (TYPE A)

Spliceable coating used on polyester double braids. Samthane Type A greatly enhances abrasion resistance. It also makes splicing used rope much easier. Available in a variety of colors for easy identification, tracking time in service, keying colors to specific operations, etc. Splices new and used utilizing the same tools and techniques for splicing uncoated rope. Coating adds approximately 3% to 5% weight to the line.

SAMTHANE (TYPE F)

Spliceable coating specially formulated for coating olefin/polyester blend ropes. Physical properties are the same as for Type A coating. Coating adds approximately 3% to 5% weight to the line.

SAMTHANE (TYPE S)

Spliceable coating used on HMPE, olefin and polyester fiber ropes. This coating adds firmness and greatly improves wear life. The coating will add approximately 3% - 5% weight to the rope.

SAMTHANE (TYPE C)

Non-spliceable jacketing type coating usually applied to specific sections of a line that will be subjected to extreme abrasion. The coating is very tough, with excellent resistance to cutting and chaffing. Usually applied to a thickness of 1/8" or more, which has a stiffening effect on the rope. This coating is applied to pre-spliced ropes and may also be used for thimble encapsulation.



SAMTHANE COATING DESCRIPTIONS

PROPERTY	Type A	Type F	Type S	Type C
Spliceability	Yes	Yes	Yes	No
Shore Hardness	NA	NA	NA	85 A
Break Strength	2,500 psi	2,500 psi	5,000 psi	5,400 psi
Elongation at Break	610%	610%	250%	450%
Modulus at 300%	600 psi	600 psi	NA	1,900 psi
Type	Waterborne Polyurethane	Waterborne Polyurethane	Waterborne Polyurethane	2-part Polyurethane

ADVANTAGES:

- Improves service life
- Reduces snagging
- Enhances abrasion resistance
- Prevents contamination
- Reduces cutting
- Color-coding for identification



FIBER CHARACTERISTICS / ROPE CONSTRUCTION

Fiber Type	Nylon	Polyester	Polypropylene	Dyneema	Technora	Vectran	Zylon (PBO)
Bulk Strength ¹	1.0	1.05	0.6	3.1 - 3.5	2.6	3.2	4
Weight	1.0	1.21	0.8	0.85	1.22	1.23	1.35
Elongation ²	1.0	0.6	0.55	0.24	0.22	0.2	0.15
Coefficient of friction ³	.10 - .12	.12 - .15	.15 - .22	0.08	.12 - .15	.12 - .15	0.18
Melting/Decomp Temperature	460 F	480 F	330 F	297 F	900 F	625 F	1200 F
Critical Temperature ⁴	350 F	350 F	250 F	150 F	450 F	300 F	480 F
Specific Gravity	1.14	1.38	0.91	0.97	1.39	1.4	1.56
Cold-Flow (Creep) ⁵	Neg	Neg	Neg to High	Neg to High	Neg	Neg	Neg
Tenacity (g/den) ⁶	7.5 - 9	8 - 9	5	32 (SK-60) 40 (SK-75)	28	23-26	42

FIBER CHARACTERISTICS (USING NYLON AS A BASIS OF 1)

¹**BULK STRENGTH:** Bulk Strength is defined as strength per circumference squared.

²**ELONGATION:** Elongation refers to elongation of fiber at break.

³**COEFFICIENT OF FRICTION:** Coefficient of Friction describes a fibers reluctance to slip or slide. Fibers with a higher coefficient of friction have a greater resistance to slip or slide.

⁴**CRITICAL TEMPERATURES:** Critical Temperature is defined as the point at which degradation is caused by temperature alone.

⁵**COLD FLOW (CREEP):** Cold Flow (Creep) is defined as fiber deformation (elongation) due to molecular slippage under a constant static load. Fibers that have this inherent characteristic will display extremely low or negligible creep if minor fluctuations occur in the rate and/or frequency of load levels.

⁶**TENACITY:** Tenacity is the measurement of the resistance of fiber to breaking and crushing.



ROPE CONSTRUCTION

BOTH CLASS I AND CLASS II ROPES CAN BE PRODUCED IN VARIOUS ROPE CONSTRUCTIONS SUCH AS: 3-STRAND, 8-STRAND, 8X3-STRAND, 12-STRAND, DOUBLE BRAIDS, OR CORE DEPENDENT BRAIDS.

All Samson ropes are categorized for testing purposes as a Class I or Class II construction.

Class I ropes are produced with non high modulus fibers that impart the strength and stretch characteristics to the rope which have tenacities of 15 grams/denier (gpd) or less and a total stretch at break of 6% or greater.

Class I Ropes are produced with traditional fibers such as: Olefin (Polypropylene or Polyethylene), Nylon, and Polyester.

Class II ropes are produced with high modulus fibers that impart the strength and stretch characteristics to the rope which have tenacities greater than 15 grams/denier (gpd) and a total stretch at break of less than 6%.

Typical Class II ropes are produced with : HMPE (Dyneema or Spectra), Aramid (Technora or Kevlar), LCP (Vectran), PBO (ZYLON), and Carbon fibers.

ALL ROPE SIZE DIMENSIONS ARE NOMINAL DIAMETERS AND DO NOT REFLECT EXACT DIMENSIONS. WEIGHTS DEPICTED ARE AVERAGE NET ROPE WEIGHTS RELAXED AND STANDARD TOLERANCES ARE PLUS OR MINUS FIVE PERCENT.

ELASTIC ELONGATION

ELONGATION DATA

IN ORDER TO ESTABLISH DEFINITIONS INVOLVING STRETCH IN ROPES, IT IS NECESSARY TO REVIEW THE TERMS UTILIZED TO DEFINE THE BASIC COMPONENTS OF STRETCH. SEE DEFINITIONS & ILLUSTRATIONS BELOW.

ELASTIC ELONGATION (E.E.)

Refers to the portion of stretch or extension of a rope that is immediately recoverable after the load on the rope is released. This recoverable tendency is a primary result of the fiber (or fibers) used as opposed to the rope construction. Each type of synthetic fiber inherently displays a unique degree of elasticity. Relatively speaking, HMPE fiber has an extremely low elasticity compared to nylon fiber.

HYSTERESIS

Refers to a recoverable portion of stretch or extension over a period of time after a load is released. In measuring elastic recovery it is the recovery that occurs immediately when a load is removed. But thereafter, a remaining small percentage of elastic recovery will occur slowly and gradually over a period of hours or days. This retardation in recovery is measured in a length/time scale and is known as hysteresis or recovery over time.

PERMANENT EXTENSION (P.E.)

AFTER RELAXED

Refers to that portion of extension which, due to construction deformation (compacting of braid and helical changes) and some plastic deformation of the yarn fibers, prevents the rope returning to the original length.

PERMANENT EXTENSION (P.E.)

WHILE WORKING

Is the amount of extension which exists when stress is removed but no time is given for hysteresis recovery. It includes the non-recoverable and hysteresis extension as one value and represents any increase in the length of a rope in a constant working situation such as during repeated surges in towing or other similar cyclical operations. The percentage of P.E. over the working load range is generally in order of four or six percent for braided ropes and two to three times as much for plaited. However, it will vary slightly with different fibers and rope constructions. In some applications, such as subsurface mooring or devices that demand precise depth location and measurement, allowances must be made for this factor.

COLD FLOW (CREEP)

Refers to fiber deformation (elongation) due to molecular slippage under a constant static loading situation. Fibers that have this inherent characteristic will display extremely lower or negligible creep if minor fluctuations occur in the rate and/or frequency of load levels.

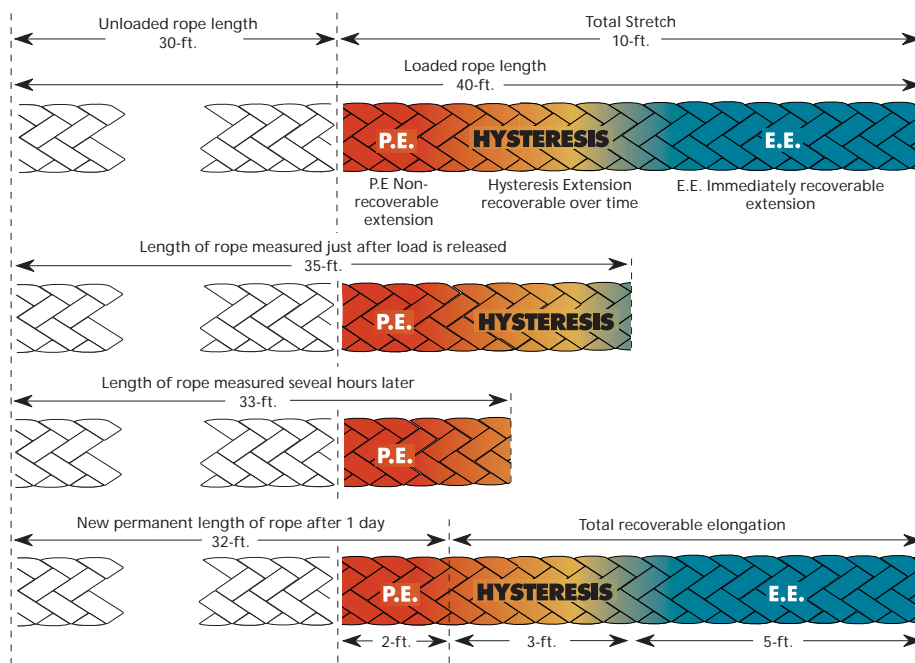

PUBLISHED ELASTIC ELONGATION DATA: ALL REPORTED PERCENTAGES ARE AVERAGES BASED ON TESTS OF NEW ROPE STABILIZED FROM 200D². TESTED ROPES ARE STABILIZED BY BEING CYCLED 50 TIMES AT EACH STATED PERCENTAGE OF ITS AVERAGE BREAK STRENGTH.

ROPE HANDLING

REMOVING ROPE FROM REEL OR COIL

Synthetic-fiber ropes are normally shipped on reels for maximum protection while in transit. The rope should be removed from the reel by pulling it off the top while the reel is free to rotate. This can be accomplished by passing a pipe through the center of the reel and jacking it up until the reel is free from the deck. Rope should never be taken from a reel lying on its side. If the rope is supplied on a coil, it should always be uncoiled from the inside so that the first turn comes off the bottom in a counter-clockwise direction.

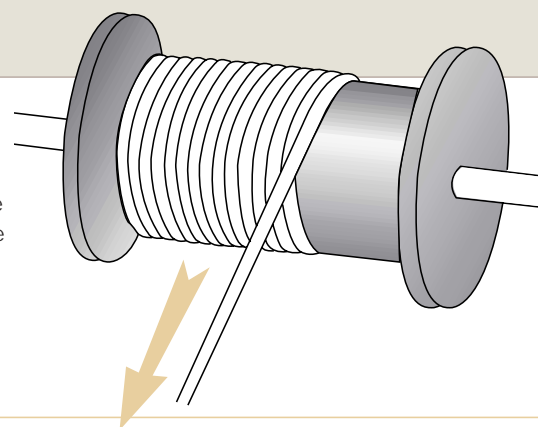

AVOID KINKING & HOCKLING

The continuous use of a line on one side of a winch or windlass is a common abuse which can render a line useless in a comparatively short time. Repeated hauling of a line over a winch in a counterclockwise direction will extend the lay of the rope and simultaneously shorten the twist of each strand. As this action continues, kinks (or hockles) will develop. Once these hockles appear, they cannot be removed and the rope is permanently damaged at the point of hocking.

If, on the other hand, the line is continuously hauled over a winch in a clockwise direction, the rope lay is shortened and the rope becomes stiff and will kink readily.

To avoid detrimental conditions, the direction of turns over the winch should be alternated regularly. Clockwise turns are recommended for the initial use of a new line. If this practice is observed, the original rope balance will be maintained and the lines will have a much longer useful life.

This condition also arises in the deep-sea mooring of free-rotating buoys where a three-strand rope will rotate until it spins and twists itself into hockles and eventually destroys itself. The use of swivels with three-strand ocean-towing hawsers, or transmission stringing lines, may also cause damaging hockles. The sudden release of a heavy strain may also cause hockles or hard kinks.

Excessive turns can cause kinking in any rope but hockles can occur only in the basic "twisted" ropes (three-strand, four-strand and cable-laid).

Braided and plaited ropes cannot be hocked; their inter-locking strand construction prevents the unlaying. Strands run in both directions creating a torque-free balance thus eliminating any inherent tendency toward twist or rotation. Swivels can be used safely but are seldom necessary. One word of caution here: when marrying a braided line to a twisted line (and also to wire rope) the twisted line can impart its twist to the braided line if the ropes are married without a swivel in between.

A braided or plaited rope, being torque-free, can have twist induced by constant working on winches and capstans. If a twist develops, it can easily be removed by "counter-rotating" when the rope is relaxed.



COILING & FLAKING

Three-strand ropes should be coiled in a clockwise direction (or in the direction of the lay of the rope) and uncoiled in a counterclockwise direction to avoid kinks. An alternate and perhaps better method is to flake out the line figure-eight fashion. This avoids putting twist in the line in either direction and lessens the risk of kinking.

Great care must be taken in the stowage and proper coiling of three-strand ropes to prevent the natural built-in twist of the line from developing kinks and damaging hockles.

Braided ropes on the other hand have no built-in twist and are far more resistant to kinking. Even if kinks do develop they cannot develop further into hockles.

The best method for making up braided rope for deck stowage is in figure-eight fashion either faked flat on the deck or figure-eight vertically around bulkhead cleats.

It should not be hand coiled in either direction as this merely puts turn into the line which may develop into kinks when paying-out. Remember that there is no turn or twist in the line to begin with so do not produce it by coiling.



BENDING RADIUS & WINCH INFORMATION

BENDING RADIUS

ANY SHARP BEND IN A ROPE UNDER LOAD DECREASES ITS STRENGTH SUBSTANTIALLY AND MAY CAUSE PREMATURE DAMAGE OR FAILURE. IN SIZING THE RADIUS OF BITTS, FAIRLEADS AND CHOCKS FOR BEST PERFORMANCE THE FOLLOWING GUIDELINES ARE OFFERED:

PIN OR SURFACE DIAMETER SHOULD BE: 3 TIMES ROPE DIAMETER OR MORE

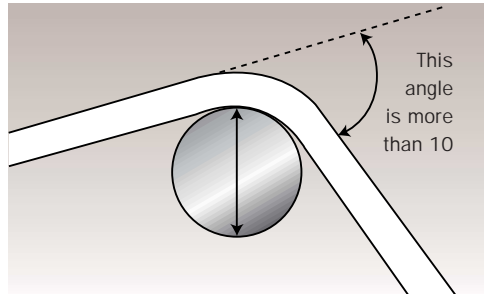

Where a rope bends more than ten degrees around bitts or chocks or is bending across any surface, the diameter of that surface should not be less than three times the diameter of the rope. Stated another way, the diameter of the surface should be at least three times the rope diameter. A four-to-one ratio (or larger) would be better yet because the durability of the rope increases substantially as the diameter of the surface over which it is worked increases.

BOLLARD WITH UNDERSIZED "HORNS"

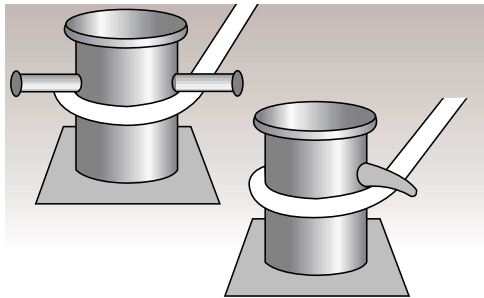

Many tugboats using eight and nine-inch circumference headlines in ship-handling work have fair size bitts (eighteen-inch diameter, etc.) which is an adequate bending radius. However, ironically, many of these bow and shoulder bitts are equipped with "horns" of a relatively small diameter (five or six-inches) and it is these horns under or over which the lines pass and bend first in many cases. This results in shortened rope life and excessive rope replacement costs.

LENGTH OF EYE SPLICE – MINIMUM

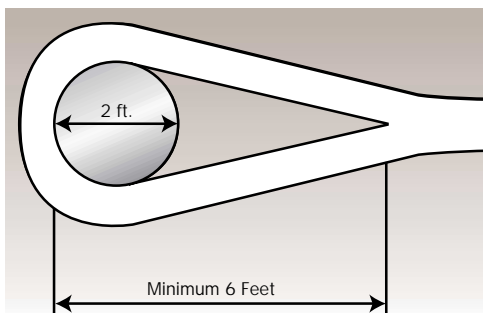

The ratio of the length of an eye splice to the diameter of the object over which the eye is to be placed (bollard, bitt, cleat, etc.) should be a minimum three-to-one relationship and preferably five-to-one. In other words, if you have a bollard two feet in diameter the eye splice should be six or ten feet in length. By using this ratio the angle of the two legs of the eye splice at its throat will not be so severe as to cause a parting or tearing action at this point (thimbles are normally designed with a three-to-one ratio).

WINCH & SHEAVE INFORMATION

WINDING ROPE

TUG ASSIST LINES:

A minimum of the first 3-4 wrap layers of rope around the winch storage drum should be installed so the rope has a close and tight fit on the drum. The installation tension on the rope should be approximately 10% of the rope's minimum breaking strength. For new rope installations, the greater the number of wrap layers installed under the suggested tension will minimize or prevent subsequent wraps from diving or burying down into lower wraps. As the rope is used, the wrap tensions may loosen, it is suggested the total rope be re-tensioned at original installation loads and thereby prevent potential downward wrap slippage. A single drum or split drum winch, should always **keep a minimum of eight wraps of rope on the drum at all times**. This is to insure that the connecting point of the rope to the winch does not under go load.

WINDING ROPE ON WINCH DRUM

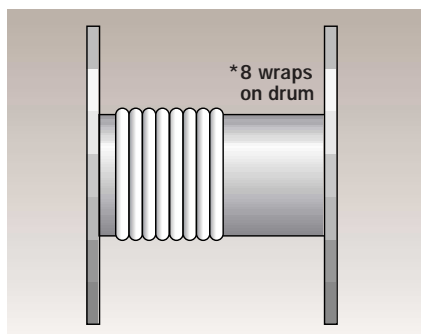

MOORING LINES:

The mooring line should be installed on the winch storage drum under tension that can be created by running the rope around a capstan, bollard, or pin. There are two key factors, it is important the rope be installed with tension and in a close tight fit on the drum to prevent rope diving or burying into the lower wrap layers. It is also important that the surface of the device used to create the tension is not abrasive to the rope and the installation speed or tension applied does not generate excessive heat build up on the rope. A single drum or split drum winch, should always **keep a minimum of eight wraps of rope on the drum at all times**. This is to ensure that the connecting point of the rope to the winch does not under go load.

In connecting the rope to the winch drum flange, it is suggested that the end of the rope either be back spliced or whipped to create better rope firmness for the flange connection bracket to compress upon.

ROPE CAPACITY OF A WINCH DRUM

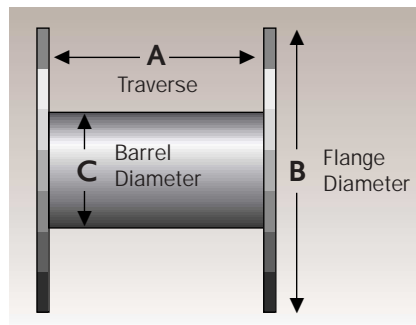

EFFECT OF ROPE DIAMETER ON DRUM CAPACITY

Rope Diameter	Feet on Drum
1-1/8"	100'
1"	125'
7/8"	165'
3/4"	225'
5/8"	325'
1/2"	510'

The formula for determining the length of rope that will fit on a winch drum is:

$$\text{Length to be stored (feet)} = \frac{A(B^2 - C^2)}{15.3 (\text{rope dia.})^2}$$

(A, B, C and rope diameter are expressed in inches; length (L) is expressed in feet.)

SHEAVE RECOMMENDATIONS

SHEAVE DIAMETERS SHOULD BE:

BRAIDED...
8 times rope diameter

TWISTED / PLAITED...
10 times rope diameter

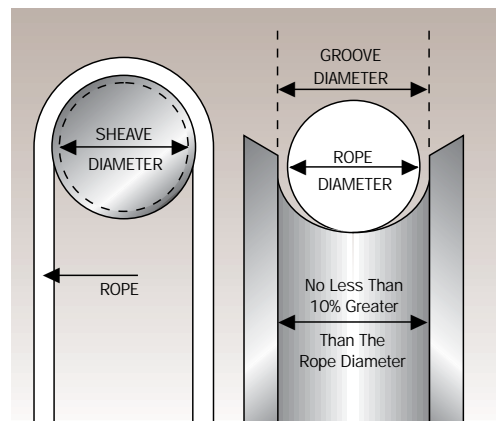

To assure maximum efficiency and safety, the sheave diameter should not be less than recommended by type of rope construction. The sheave groove diameter should be no less than 10% greater than the rope diameter and the groove should be round in shape. Sheaves with "V" shaped grooves should be avoided, as they tend to pinch and damage the rope through excessive friction and crushing of the fibers. Sheave surfaces should be kept smooth and free of burs and gouges. Bearing should be maintained to ensure smooth rotation of sheaves.

STANDARDS FOR STRENGTH & DETERMINATION

NEW ROPE TENSILE STRENGTHS

New rope tensile strengths are based on tests of new and unused spliced rope of standard construction in accordance with Samson Rope Technologies Test Methods, which conform to Cordage Institute, ASTM, and OCIMF testing procedures. All stated minimum tensile strengths are based on a 98% confidence factor. It can be expected that strengths will decrease as soon as a rope is put into use. Because of the wide range of rope use, changes in rope conditions, exposure to the many factors affecting rope behavior, and the possibility of risk to life and property, it is impossible to cover all aspects of rope applications or to make blanket recommendations as to working loads.

BREAKING STRENGTH DETERMINATION

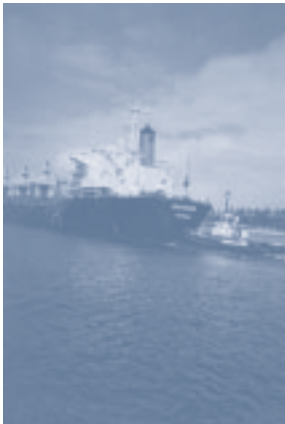

Samson Rope Technologies has prepared a comprehensive test method to determine pertinent physical characteristics of fiber ropes. The reasoning behind this is to allow our customers to fully understand how the products they purchase are tested. Easy access to this method also allows our customers to conduct tests independently, when necessary. Widely accepted methods such as ASTM D4268 and CI-1500 are very valuable tools to the cordage industry and it is not our intention to undermine these methods. As a matter of fact, *the SRT Test Method was built around the ASTM and CI methods, and complies with both.* However, these methods do not contain certain procedures that we at SRT perform everyday. Methods, such as the determination of lay lengths (PPI for braids), linear density under relaxed conditions, and specifically stating cycle loads that are dependent on fiber type, which are crucial to the construction of our products and are the basis for the information provided in our literature.

WE RECOMMEND THE SRT TESTING STANDARD FOR THE FOLLOWING REASONS:

- Complies with EN 919, ASTM D4268 and CI-1500 standards
- Has well defined details and procedures to assure consistent and reproducible data
- Generates practical measurements, applicable to real-world usage.
- Does not require data interpretation or computation based on empirical factors (e.g., realization factors, terminated vs. unterminated strengths, etc.)
- Is suitable for all types of fiber ropes

TESTING STANDARDS

All Standard Organizations have a set procedure (standard) agreed upon by the specific committee members at the time of publication. Since many of these organizations initially were regionalized, many of today's competing standards have different test procedures that met that regions needs. Since there are many different ways to report similar information, confusion proliferates when comparing and contrasting the information using competing standards. Neither specification is incorrect; JUST DIFFERENT.

ISO/BS-EN919

This international standard requires the rope's strength to be reported without the effects of the termination. For most scenarios, the rope's strength will be 10% higher than the actual breaking strength of a spliced rope. This reporting technique gives an accurate measure of the rope's properties, but additional computation is needed when terminations are required.

STANDARDS



WORKING LOADS

Working loads are for rope in good condition with appropriate splices, in noncritical applications and under normal service conditions. Working loads are based on a percentage of the approximate breaking strength of new and unused rope of current manufacture. For the three-strand, eight-strand, twelve-strand and double braid rope products depicted in this catalog, when used under normal conditions, the working load percentage is 20% of published strengths. Normal working loads do not cover dynamic conditions such as shock loads or sustained loads, nor do they cover where life, limb or valuable property are involved. In these cases a lower working load must be used.

A higher working load may be selected only with expert knowledge of conditions and professional estimates of risk, if the rope has been inspected and found to be in good condition, and if the rope has not been subject to dynamic loading (such as sudden drops, snubs or pickups), excessive use, elevated temperatures, or extended periods under load.

NORMAL WORKING LOADS

Normal working loads are not applicable when rope has been subject to dynamic loading. Whenever a load is picked up, stopped, moved or swung there is an increased force due to dynamic loading. The more rapidly or suddenly such actions occur, the greater the increase will be. In extreme cases, the force put on the rope may be two, three, or even more times the normal load involved. Examples could be ropes used as a tow line, picking up a load on a slack line, or using rope to stop a falling object. Dynamic effects are greater on a low elongation rope such as polyester than on a high elongation rope such as nylon, and greater on a short rope than on a long one. Therefore, in all such applications normal working loads as given do not apply.

STANDARDS FOR STRENGTH & DETERMINATION

STANDARDS, CONT.



DYNAMIC LOADING

For dynamic loading applications involving severe exposure conditions, or for recommendations on special applications, consult the manufacturer.

DANGER TO PERSONNEL

Persons should be warned against the serious danger of standing in line with a rope under tension. Should the rope part, it may recoil with considerable force. In all cases where any such risks are present, or where there is any question about the load involved or the condition of use, the working load should be substantially reduced and the rope properly inspected before every use.



SPLICING & KNOTS

Splices should be used instead of knots whenever possible because knots can decrease rope strength up to fifty percent. When splices are used, always use the manufacturer's recommended splicing procedures. When knots are used, be sure to take into consideration the knot's corresponding reduction to the rope strength and adjust your working load accordingly.



ROPE INSPECTION

Avoid using rope that shows signs of aging and wear. If in doubt, destroy the used rope.

No type of visual inspection can be guaranteed to accurately and precisely determine the actual residual strength. When the fibers show wear in any given area, the rope should be re-spliced, downgraded, or replaced. Check the line regularly for frayed strands and broken yarns. Pulled strands should be re-threaded into the rope if possible. A pulled strand can snag on a foreign object during rope operation.

Both outer and inner rope fibers contribute to the strength of the rope. When either is worn, the rope is naturally weakened. Open the strands of the rope and look for powdered fiber, which is one sign of internal wear. A heavily used rope will often become compacted or hard which indicates reduced strength. The rope should be discarded if this condition exists.



AVOID ALL ABRASIVE CONDITIONS

All rope will be severely damaged if subjected to rough surfaces or sharp edges. Chocks, bits, winches, drums and other surfaces must be kept in good condition and free of burrs and rust. Pulleys must be free to rotate and should be of proper size to avoid excessive wear.

AVOID CHEMICAL EXPOSURE

Rope is subject to damage by chemicals. Consult the manufacturer for specific chemical exposure, such as solvents, acids, and alkalis. Consult the manufacturer for recommendations when a rope will be used where chemical exposure (either fumes or actual contact) can occur.



AVOID OVERHEATING

Heat can seriously affect the strength of synthetic ropes. The temperatures at which 50% strength loss can occur are: Polypropylene 250° F, Nylon 350° F, Polyester 350° F. When using rope where the temperature exceeds these levels (or if it is too hot to hold), consult the manufacturer for recommendations as to the size and type of rope for the proposed continuous heat exposure conditions. When using ropes on a capstan or winch, care should be exercised to avoid surging while the capstan or winch head is rotating. The friction from the slippage causes localized overheating which can melt or fuse synthetic fibers, resulting in severe loss of tensile strength.

STORAGE

All rope should be stored in a clean, dry, out of direct sunlight, and away from extreme heat. It should be kept off the floor on racks to provide ventilation underneath. Never store on a concrete or dirt floor, and under no circumstances should cordage and acid or alkalis be kept in the same vicinity. Some synthetic rope (in particular polypropylene and polyethylene) may be severely weakened by prolonged exposure to ultraviolet (UV) rays unless specifically stabilized and/or pigmented to increase UV resistance. UV degradation is indicated by discoloration and the presence of splinters and slivers on the surface of the rope.

ROPE INSPECTION & RETIREMENT

ROPE RETIREMENT

ROPE LIFE FACTORS: THERE ARE BASICALLY THREE STEPS TO CONSIDER IN PROVIDING THE LONGEST POSSIBLE SERVICE LIFE FOR ROPES, THE SAFEST CONDITIONS AND LONG RANGE ECONOMY: SELECTION, USAGE, AND RETIREMENT.

The use of rope for any purpose subjects it to friction, bending and tension. All rope hardware, sheaves, rollers, capstans, cleats, as well as knots are, in varying degrees, damaging to the rope. It is important to understand that rope is a moving, working, strength member and even under the most ideal conditions will lose strength during use in any application. Maximizing the safety of rope performance is directly related to how strength loss is managed and making sure ropes are retired from service before they can create a dangerous situation. Ropes are serious working tools and used properly will give consistent and reliable service. The cost of replacing a rope is extremely small when compared to the physical damage or personnel injury a worn out rope can cause.

SELECTION

STEP 1: SELECT THE RIGHT ROPE FOR THE JOB IN THE FIRST PLACE.

Selecting a rope involves evaluating a combination of factors. Some of these factors are straightforward like comparing rope specifications. Others are less qualitative like a preference for a specific color or how a rope feels in your hand. Cutting corners, reducing application factors, sizes or strengths on an initial purchase creates unnecessary replacements, potentially dangerous conditions and increases long term costs. Fiber and construction being equal, a larger rope will out last a smaller rope – because of the greater surface wear distribution. By the same token, a stronger rope will out last a weaker one – because it will be used at a lower percentage of its break strength with less chance of over stressing.

STRENGTH

When given a choice between ropes, select the strongest of any given size. A load of 200 pounds represents 2% of the strength of a rope with a breaking strength of 10,000 pounds. The same load represents 4% of the strength of a rope that has a breaking strength of 5,000 pounds. The weaker rope is having to work harder and as a result will have to be retired sooner.

ELONGATION

It is well accepted that ropes with lower elongation under load will give you better load control, a big help at complicated job sites. However, ropes with lower elongation that are shock loaded, like a lowering line, can fail without warning even though it appears to be in good shape. Low elongating ropes should be selected with the highest possible strength. Both twisted ropes and braided ropes are suitable for rigging. Twisted rope has lower strength and more stretch. Braided rope has higher strength and lower stretch.

FIRMNESS

Select ropes that are firm and round and hold their shape during use. Soft or mushy ropes will snag easily and abrade quickly causing accelerated strength loss. Because the fibers are in a straighter line which improves strength but compromises durability, a loose or mushy rope will almost always have higher break strengths than a similar rope that is firm and holds its shape.

CONSTRUCTION & ABRASION

Rope construction plays an important role in resistance to normal wear and abrasion. Braided ropes have a basically round, smooth construction that tends to flatten out somewhat on a bearing surface. This distributes the wear over a much greater area, as opposed to the crowns of a three-strand or, to a lesser degree, on an eight-strand rope.

All ropes should be protected against sharp and abrasive surfaces. Wire ropes tend to score and gouge chocks and bits creating cutting edges that can damage synthetic ropes. Weld beads on repaired capstans, fairleads, etc. are equally damaging unless dressed down smoothly.

ROPE INSPECTION & RETIREMENT

USAGE

STEP 2: USE ROPE PROPERLY; DO NOT ABUSE OR SHOCK LOAD IT, OBSERVE RECOMMENDED USAGE FACTORS FOR BENDING AND WORK LOADS. KEEP ROPES CLEAN AND ELIMINATE ABRASION WHENEVER POSSIBLE.

WORKING LOADS

Working loads are the loads that a rope is subjected to in everyday activity. They are normally expressed as a percentage of new rope strength and should not exceed 20%. A point to remember is that a rope may be severely overloaded or shock loaded in use without breaking. However, damage and strength loss may have occurred without any visible indication. The next time the rope is used under normal working loads the acquired weakness can cause it to break. Do not blame the rope, it was simply overloaded and failed from what is known as fatigue.

RECOMMENDED WORK LOAD LIMIT (FOR CATALOGUED ROPES)

Construction	Working Load (% of break strength)
3-Strand	20%
8-Strand	20%
12-Strand	20%
Double Braid	20%

BENDING

Any sharp bend in a rope under load decreases its strength substantially and may cause premature damage and failure. Sheave diameters on rotating sheave blocks should be 10 times the rope diameter for twisted ropes and 8 times the rope diameter for braided ropes. The diameter on fixed pin terminations should be at least 3 times the rope diameter (i.e., the pin diameter for 1/2" diameter rope should be no less than 1-1/2" in diameter).

KNOTS

While it is true that a knot reduces rope strength, it is also true that a knot is a convenient way to accomplish rope attachment. The strength loss is a result of the tight bends that occur in the knot. With some knots, ropes can lose up to 50% of their strength. It is vital that the reduction in strength by the use of knots be taken into account when determining application. To avoid knot strength reduction, it is recommended that a rope be spliced according to the manufacturer's instructions. Splice terminations are used in all our ropes to determine new and unused tensile strengths. Therefore, whenever possible, spliced terminations should be used to maximize the rope strength for new and used ropes.

ROPE STORAGE

Keep ropes clean and dry as possible and store them away from chemical contaminants and heat sources.

SHOCK LOADS

Shock loads are simply a sudden change in tension from a state of relaxation or low load to one of high load. Any sudden load that exceeds the work load by more than 10% is considered a shock load. The further an object falls, the greater the impact. Synthetic fibers have a memory and retain the effects of being overloaded or shock loaded and can fail at a later time even though loaded within the work load range.

ROPE INSPECTION & RETIREMENT

RETIREMENT **STEP 3: RETIRE ROPE FROM USE WHEN IT HAS REACHED ITS DISCARD POINT.**

One of the most frequently asked questions is “When should I retire my rope?” The most obvious answer is before it breaks. But, without a thorough understanding of how to inspect it and knowing the load history, you are left making an educated guess. Unfortunately, there are no definitive rules nor industry guidelines to establish when a rope should be retired because there are so many variables that affect rope strength. Factors like load history, bending radius, abrasion, chemical exposure or some combination of those factors, make retirement decisions difficult. Inspecting your rope should be a continuous process of observation before, during and after each use. In synthetic fiber ropes the amount of strength loss due to abrasion and/or flexing is directly related to the amount of broken fiber in the rope’s cross section. After each use, look and feel along every inch of the rope length inspecting for abrasion, glossy or glazed areas, inconsistent diameter, discoloration, and inconsistencies in texture and stiffness.

UNDERSTANDING THE ROPE DESIGN/CONSTRUCTION

It is first important to understand the design of the specific rope in use. Most ropes are designed to have features specifically tailored to their application. These features can lead to misconceptions during visual inspections. When a rope has a braided cover, it is only possible to visually inspect the cover (which, at best, carries only 50% of the load). Rope designs utilizing HMPE fibers will show initial rapid abrasion until the rope has a fuzzy appearance – this appearance actually acts as a protective layer.

DETERMINE THE AVERAGE CONDITION OF THE ROPE

The average condition of a rope can be an important factor in determining the rope’s retirement. To determine the average condition, walk the entire length of the rope and document its overall condition. Many ropes can be classified by the total amount of overall wear and cleanliness. Below are three different rope conditions depicting a new rope (*fig. 1*), a used rope (*fig. 2*), and a severely abraded rope (*fig. 3*).

Please note that there are various degrees of rope conditions not shown here.



FIG. 1 New rope



FIG. 2 Used rope



FIG. 3 Severely abraded rope

ABRASION

When the rope is first put into service the outer filaments of the rope will quickly fuzz up (*fig. 2*). This is the result of these filaments breaking and this roughened surface actually forms a protective cushion and shield for the fibers underneath. This condition should stabilize, not progress. If the surface roughness increases (*fig. 3*), excessive abrasion is taking place and strength is being lost. As a general rule for braided ropes, when there is 25% or more wear from abrasion the rope should be retired from service. In other words, if 25% or more of the fiber is broken or worn away the rope should be removed from service. With three-strand ropes, 10% or more wear is accepted as the retirement point.

LOCATE AREAS DEVIATING FROM AVERAGE

Many times a rope will have areas that are routinely used around a bit, through a chock, or buried on the winch drum. These areas typically have different wear patterns than the average condition of the rope. Pay close attention to these areas in the future and frequently examine them for rapid changes in appearance. Look closely at both the inner and outer fibers. When either is worn the rope is obviously weakened. Open the strands and look for powdered fiber which is one sign of internal wear. Estimate the internal wear to estimate total fiber abrasion. If total fiber loss is 20%, then it is safe to assume that the rope has lost 20% of its strength as a result of abrasion. Internal abrasion can be determined by pulling one strand away from the others and looking for powdered or broken fiber filaments (*fig. 4 & fig. 5*). To determine the extent of outer fiber damage from abrasion, a single strand in the all abraded areas should be examined. Each examination of a surface yarn should be compared to an internal yarn (*fig. 6*).



FIG. 4



FIG. 5



FIG. 6

ROPE INSPECTION & RETIREMENT

It should be noted that comparing diameters of the yarns does not give an accurate measure of the retained strength. Since the strength should depend on the cross-sectional area of the yarn, a diameter difference alone will underestimate the true abrasion reduction. If the diameter of the abraded yarn is 1/2 the diameter of the internal yarn, the strength of the abraded yarn is nearly 1/4 that of the internal yarn. Determining the extent of fiber loss due to abrasion can be difficult. Since all the strands are twisted, the outer fibers which are the most prone to abrasion damage, rotate through the rope's length. Therefore on a single strand, the fibers that have been abraded on one pick, are not necessarily the fibers being abraded on the next. However, over a long distance, a single yarn could have the majority of fiber loss due to abrasion.

GLOSSY OR GLAZED AREAS

Glossing or glazing can occur from two different mechanisms. The most common and relatively benign form of glossing or glazing on a rope is generally caused by compression, which typically occurs when the rope is wound on the winch drum, around bits, or through chocks or staples. This form of glossing can be determined on 8 and 12 strand products by compressing the rope length wise forming a "bird cage" (fig. 7) After numerous "bird cage" cycles the glossy region will become more pliable and begin to resemble normal rope. If the glazed section remains hardened, this could be a sign of heat damage. Heat damaged rope typically has more strength loss than the amount of melted fiber indicates. Fibers adjacent to the melted areas are probably damaged from excessive heat even though they appear normal. It is reasonable to assume that the melted fiber has damaged an equal amount of adjacent unmelted fiber.



FIG. 7 Bird cage



FIG. 8 Compressed area

INCONSISTENT DIAMETER

Inspect for flat areas, bumps or lumps. This can indicate core or internal damage from overloading or shock loads and is usually sufficient reason to replace the rope.

DISCOLORATION

With use, all ropes get dirty. Be on the lookout for areas of discoloration which could be caused by chemical contamination. Determine the cause of the discoloration and replace the rope if it is brittle or stiff.

INCONSISTENCY IN TEXTURE & STIFFNESS

Can indicate excessive dirt or grit embedded in the rope or shock load damage and is usually reason to replace the rope.

TEMPERATURE

When using rope, friction can be your best friend or worst enemy if it is not managed properly. By definition, friction creates heat, the greater the friction the greater the heat buildup. Heat is an enemy to synthetic fiber and elevated temperatures can drastically reduce the strength and/or cause rope melt-through. The critical and melting temperatures for synthetic fibers are listed below:

CRITICAL & MELTING TEMPERATURE





Fiber Type	Critical	Melting
Polypropylene	250° F	330° F
HMPE	150° F	297° F
Technora	450° F	900° F*
Nylon	250° F	460° F
Polyester	350° F	480° F
Manila	180° F	350° F*

* CHARRING POINT

High temperatures can be achieved when surging rope on a capstan or drum end, checking ropes on bits, and running over stuck or non-rolling sheaves or rollers. Each rope's construction and fiber type will yield a different coefficient of friction (reluctance to slip) in a new and used state. It is important to understand the operational demands and insure the size, rope construction and fiber type be taken into account to minimize heat buildup. Never let ropes under tension rub together or move relative to one another. Enough heat to melt the fibers can buildup and cause the rope to fail as quickly as if it had been cut with a knife. Always be aware of areas of heat buildup and take steps to minimize it; under no circumstances let any rope come in contact with a steam line or any other hot surfaces. The strength of a used rope can be determined by testing but the rope is destroyed in the process so the ability to determine the retirement point before it fails in service is essential. That ability is based on a combination of education in rope use and construction along with good judgment and experience.

ROPE RETIREMENT VISUAL GUIDE & CHECK LIST

VOLUME REDUCTION

<p>EXAMPLE 1</p>  <p>Rope displaying original bulk.</p>	<p>EXAMPLE 2</p>  <p>Rope displaying 25% strand volume reduction from abrasion – rope should be retired from service.</p>
<p>EXAMPLE 3</p>  <p>Rope strands showing full volume.</p>	<p>EXAMPLE 4</p>  <p>Rope strands reduced by 25% abrasion. Pulled strands should be worked back into the rope so they won't continue to snag and eventually cut.</p>

*Amount of volume reduction that indicates retirement depends on rope construction. refer to "check list" below.

CUT STRANDS

<p>EXAMPLE 1</p>  <p>Rope displays two adjacent cut strands. This rope should either be retired or the cut section should be removed and the remaining rope re-spliced.</p>

*Number of cut strands that indicate retirement depends on the rope construction. See "check list" below.

COMPRESSION

<p>EXAMPLE 1</p> <p>Rope exhibits fiber-set from compression. A slight sheen is visible.</p> 	<p>EXAMPLE 2</p> <p>This is not a permanent characteristic and can be eliminated by flexing the rope. This conditions should not be confused with glazed or melted fiber (see Melting below).</p> 
--	---

MELTING OR GLAZING

<p>EXAMPLE 1</p> <p>Damage depicted at left caused by excessive heat which melted and fused the fibers. This area will be extremely stiff.</p> 	<p>EXAMPLE 2</p> <p>Unlike fiber compression, melting damage cannot be mitigated by flexing the rope. Melted areas must be cut out and rope respliced or the rope must be retired.</p>
---	--

CHECK LIST

CONDITION	DISCARD POINT	CONDITION	DISCARD POINT
1. ORIGINAL ROPE BULK REDUCED BY ABRASION:		4. FIBER STRANDS CUT:	
• Double braid* cover by 50%	✓	• Double braid* by three or more adjacent strands cut	✓
• Twelve-strand braid by 25%	✓	• Twelve-strand braid by two or more adjacent strands cut	✓
• Eight-strand plait by 25%	✓	• Eight-strand plait by one or more adjacent strands cut	✓
• Three-strand by 10%	✓	• Three-strand by one or more adjacent strands cut	✓
• Localized or extended areas	✓	5. INCONSISTENCY OF TEXTURE:	
2. DIAMETER INCONSISTENCY:		• Localized or extended areas of stiffness	✓
• Localized diameter reduction	✓	6. GLOSSY OR GLAZED FIBER:	
• Flat areas	✓	• Localized or extended areas	✓
• Lumps and bumps in rope	✓		
3. DISCOLORATION:			
• Localized or extended areas caused by chemical contamination	✓		

* Refers to double braids that have both core and cover strength members.

GLOSSARY

ABRASION RESISTANCE: The ability of a fiber or rope to withstand surface wear and rubbing due to motion against other fibers of rope components (internal abrasion) or a contact surface, which can be a portion of the rope itself (external abrasion).

BLOCK CREEL: A method of rope making whereby a given length of rope is produced from a ropemaking machine where all the subcomponents of the rope structure are continuous without splices. The term arises from filling all creels or bobbins to maximum (block creels) and ending rope making when the first one empties.

BRAID: *n.* A rope or textile structure formed by a braiding process. *v.* The intertwining of strands in a braiding process to produce a tubular rope structure.

BRAID, DOUBLE: A rope constructed from an inner hollow braided rope (core) which has another hollow single braided rope constructed around its exterior (cover). Core and cover may be either plain or twill braid and both share any load on the rope, but not necessarily in equal amounts. Also called "braid-on-braid".

BRAID, HOLLOW (Also: Braid, Single; Braid, Diamond): A single braid rope construction of either plain or twill braid. The center is hollow. On the surface all strands are inclined to the axis.

BRAIDER SPLICE: In a braided rope, the continuation of a single interrupted strand (or multiple strand) with another identical strand, which is braided from the same carrier. The interrupted and replacement strands are arranged in parallel over some distance, and are buried, or tucked, into the braid so as to secure them into the braid. To maintain maximum strength, the strands should overlap one another for a sufficient distance.

BREAKING LENGTH: A convenient term for comparing the strength to weight ratio of textile structures from one product to another. The calculated length of a specimen whose weight is equal to the breaking load.

BREAKING STRENGTH: For cordage, the nominal force (or load) that would be expected to break or rupture a single specimen in a tensile test conducted under a specified procedure. On a group of like specimens it may be expressed as an average or as a minimum based on statistical analysis.

Note: Breaking force refers to an external force applied to an individual specimen to produce rupture, whereas breaking strength preferable should be restricted to the characteristic average force required to rupture several specimens of a sample. While the breaking strength is numerically equal to the breaking force for an individual specimen, the average breaking force observed for two or more specimens of a specific sample is referred to or used as the breaking strength of the sample.

BREAKING STRENGTH, MINIMUM: The Cordage Institute standard. A value based on a statistically significant number of breaking load tests and the standard deviation used to establish the minimum value.

CLASS I ROPE: Rope constructions that are produced with non high modulus fibers that impart the strength and stretch characteristics to the rope which have tenacities of 15 grams/denier (gpd) or less and a total stretch at break of 6% or greater. Typical Class I ropes are produced with traditional fibers such as: Olefin (Polypropylene or Polyethylene), Nylon, and Polyester. These fibers can be used in combination or singularly in the various rope constructions such as: 3-strand, 8-strand, 12-strand braids, double braids, or core dependent braids.

CLASS II ROPE: Rope constructions that are produced with high modulus fibers that impart the strength and stretch characteristics to the rope which have tenacities greater than 15 grams/denier (gpd) and a total stretch at break of less than 6%. Typical Class II ropes are produced with: HMPE (Dyneema or Spectra), Aramid (Technora or Kevlar), LCP (Vectran), PBO (ZYLON), and Carbon fibers. These fibers can be used in combination or singularly in the various ropes constructions such as 3-strand, 8-strand, 12-strand, double braids, or core dependent braids.

CORE DEPENDENT BRAIDS: Cover braided rope constructions that utilize an internal core member or members to create the strength and stretch characteristics of the rope. The external covering braid's primary function is to contain the core or cores and create the degree of rope firmness desired. Based on the fiber or combination of fibers used in the covering braid, the following characteristics of the rope can be altered: co-efficient of friction, wear resistance, specific gravity, and heat resistance. Core Dependent Braided ropes typically have internal strength members that are produced with: parallel bundled fiber cores, a single braid core, multiple braid cores, or multiple 3 strand cores. This type of rope construction can be produced with traditional fibers or high modulus fibers or combinations of both fiber groups and offers the potential of creating a wide range of design parameters.

CYCLE LENGTH: The length along the axis required for a strand to make one revolution around the rope.

DEGRADATION: The loss of desirable physical properties by a textile material due to some process of physical/chemical phenomenon.

DENIER: The system used internationally for the numbering of silk and man-made filament yarns, except glass yarns. It is the primary unit for determining the size of a yarn and is based on its linear density. Officially, it is defined as the number unit weights of 0.05 grams per 450-meter length. Denier is equivalent numerically to the number of grams per 9,000 meters. In the English numbering system, 1 denier equals 4,464,528 yards to the pound. Denier is also used to indicate the thickness of a man-made fiber staple. For example, a staple is said to be 3 denier if 1,488,176 linear yards of the staple (were it continuous) would weigh 1 pound. The metric equivalent is Tex, the grams mass of 10,000 meters of yarn.

DYNAMIC LOAD (for cordage): Any rapidly applied load that increases the load significantly above the normal static load when lifting or suspending a weight. Dynamic effects are greater on a low elongation rope such as manila than on a higher elongation rope such as nylon, and greater on a shorter rope than on a longer one. Also, any rapidly applied load to cordage that may change its properties significantly when compared to slowly applied loads.

EXTRUSION: For polymer filaments. The process of producing filaments by forcing a polymer through a die.

FATIGUE: The tendency of a material to weaken or fail during alternate tension-tension or tension-compression cycles. In cordage, particularly at loads well below the breaking strength, this degradation is often caused by internal abrasion of the fibers and yarns but may also be caused by fiber damage due to compression. Some fibers develop cracks or splits that cause failure, especially at relatively high loads.

FIBER: A long, fine, very flexible structure that may be woven, braided, or twisted into a variety of fabrics, twine, cordage or rope.

FINISH: An oil, emulsion, lubricant or the like, applied to fibers to prevent damage during textile processing or to improve performance during use of the product.

HMPE SYNTHETIC FIBER: Industry acronym for Dyneema High Modulus PolyEthylene fibers. Within the HMPE category, there may be different grades of HMPE fibers. For example, DSM offers Dyneema SK-60 or SK-75 grade fibers. Each grade differs by tenacity or other ratings.

HYDROLYSIS: The attack of the water ions on polymeric molecules, which results in polymer chain scission and loss of the fiber's physical properties.

LAID ROPES: Ropes made by twisting of three or more strands together with the twist direction opposite that of the strands.

LAY LENGTH: The actual distance required to make one complete revolution around the axis in any element in a strand, cord or rope.

LIQUID CRYSTAL POLYMER (LCP): A thermoplastic multifilament yarn spun from a proprietary liquid crystal polymer. LCP fiber is five times stronger than steel and ten times stronger than aluminum for its weight. It has no creep and excellent chemical resistance.

MBS: An acronym used in this catalog for identifying Minimum Break Strength of rope products in load force of Lbs., Tons, or Tonnes.

MONOFILAMENT: A yarn consisting of one or more heavy, coarse, continuous filaments produced by the extrusion of a polymeric material suitable for fiber production.

MULTIFILAMENT: A yarn consisting of many fine continuous filaments produced by the spinning of a polymeric material suitable for fiber production.

NOMINAL SIZE: A designation that has been determined by the measurement of another property. For rope, diameter is considered a nominal property and is based upon the measurement of the linear density of the rope in accordance with some standard.

NYLON (PA) FIBER: A manufactured fiber in which the fiber-forming substance (polyamide) is characterized by recurring amide groups as an integral part of the polymer chain. The two principal types of nylon fiber used in rope production are type 66 and type 6. The number six in the type designation is indicative of the number of carbon atoms contained in the reactants for the polymerization reaction.

GLOSSARY

pH: Value indicating the acidity or alkalinity of a material. A pH of 7.0 is neutral; less than 7.0 is acid, and more than 7.0 is basic.

POLYESTER (PET) FIBER: A manufactured fiber in which the fiberforming substance (polyester) is characterized by a long chain polymer having 85% by weight of an ester of a substituted aromatic carboxylic acid. The most frequently used acid is terephthalic acid in the presence of ethylene glycol.

POLYETHYLENE (PE): A polyolefin resin, produced from the polymerization of ethylene gas, and used in the production of manufactured fiber. Polyethylene is similar to polypropylene in its properties but has a higher specific gravity and a lower melting point.

POLYETHYLENE, EXTENDED CHAIN (HMPE): A polyolefin fiber that is characterized by the gel spinning of a very high and narrow molecular weight distribution fiber to produce extremely high tenacity material. The strength of the fiber is approximately 10 times that of steel on a weight-for-weight basis.

POLYMER: A long chain molecule from which man-made fibers are derived; produced by linking together molecular units called monomers.

POLYPROPYLENE (PP): A polyolefin resin, produced from the polymerization of propylene gas, and used in the production of manufactured fiber. Polypropylene may be extruded into a number of fiber forms for use by the ropemaker.

ROPE, EIGHT-STRAND PLAITED: A rope of which the strands are generally plaited in pairs, and mainly used for marine purposes.

ROPE, FIBER: A compact but flexible, torsionally balanced structure produced from strands which are laid, plaited or braided together to produce a product which serves to transmit a tensile force between to points. Generally greater than 3/16" diameter.

SPECIFIC GRAVITY: Ratio of the mass of a material to the mass of an equal volume of water. The specific gravity of fresh water is 1.0 and salt water is 1.025. Something is said to be neutrally buoyant when its specific gravity is equal to that of the medium into which it is placed.

SPLICE: The joining of two ends of yarn, strand or cordage by intertwining or inserting these ends into the body of the product. An eye splice may be formed by using a similar process to join one end into the body of the product.

STRAND: The largest individual element used in the final rope-making process and obtained by joining and twisting together several yarns or groups of yarns.

STAPLE: Natural fibers of cut lengths from filaments of man-made fibers. The staple length of natural fibers varies from less than 1-inch for some cotton fibers to several feet for some hard fibers. Man-made fibers are cut to a definite length, usually about 1-1/2 inches but occasionally down to 1-inch, so they can be processed on the cotton, woolen and worsted systems. The term staple (fiber) is used in the textile industry to distinguish natural or cut length man-made fibers from filament.

TENSILE STRENGTH, MINIMUM: A value based on a large number of breaking force tests representing a value which is two standard deviations below the mean. See: Breaking Strength, Minimum.

TON (tn or T or t) 1: A traditional unit of weight equal to 20 hundredweight. In the United States, there are 100 pounds in the hundredweight and exactly 2,000 pounds (907.185 kilograms) in the ton. In Britain, there are 112 pounds in the hundred weight and 2,240 pounds (1016.047 kilograms) in the ton. To distinguish between the two units, the British ton is called a long ton and the American one is called the short ton. The best symbol to use for this unit is tn. The symbol t, traditionally used for the long or short ton, is now reserved for the metric system.

TON (t) 2: A metric unit of mass, equal to 1000 kilograms, or approximately 2204.632 pounds avoirdupois. This metric ton is a bit smaller than the British long ton. The metric ton is now known officially as the tonne (see below).

TONNE (t): A metric unit of mass equal to 1000 kilograms or approximately 2204.632 pounds avoirdupois. The SI uses this French spelling for the metric ton (see ton [2] above) to distinguish it clearly from the long and short tones of customary English usage. Large masses are often stated as multiples of the tonne, although technically the SI requires that masses be stated as multiples of the gram. Thus a mass of 10³ tonnes = 10⁶ kg = 109g is often called 1 kilotonne (kt) instead of 1 gigagram. In the United States, the Department of Commerce recommends that the tonne be called the metric ton.

TORQUE: A force or a combination of forces that produces or tends to produce a twisting or rotating motion. When used in describing the performance or characteristic of yarn, the term torque refers to that character which tends to make it turn on itself as a result of twisting.

TWIST: The number of turns about the axis applied to a fiber, yarn, strand or rope over a given length to combine the individual elements into a larger and stronger structure. The direction of rotation about the axis denoted as "S" (left hand) or "Z" (right hand) twist.

TWIST, BALANCED: In a plied yarn or cord, an arrangement of twist which will not cause the yarn or cord to twist on itself when held in the form of an open loop.

TWISTING: The process of combining tow or more parallel textile elements by controlling the lineal and rotational speeds of the material to produce a specific twist level.

WORKING LOAD LIMIT: The working load that must not be exceeded for a particular application as established by an engineer, supervisor, regulatory or standards setting agency.

YARN: A generic term for a continuous strand of textile fibers, filaments or material in a form suitable for intertwining to form a textile structure via any one of a number of textile processes.

YARN, SINGLE: The simplest textile structure available for processing into rope, twine or cordage.

YARN, PLYED: A yarn formed by twisting together two or more single yarns in one operation in a direction opposite to the twist direction of the single yarns to produce a balanced structure.

CONVERSION CHART

SIZE

Inches x 25.40 = Millimeters
Millimeters x 0.03937 = Inches

LENGTH

Feet x 0.3048 = Meters
Meters x 3.2808 = Feet

WEIGHT

Pounds x 0.4536 = Kilograms
Kilograms x 2.2046 = Pounds

YARDAGE

Pounds per 100 Feet x 1.4882 = Kilograms per 100 Meters
Kilograms per 100 Meters x 0.6720 = Pounds per 100 Feet

STRENGTH

Kips x 1000 = Pounds Force
Pounds Force x 4.448 = Newtons
Newtons x 0.2248 = Pounds Force
Kilograms Force x 9.806 = Newtons
Newtons x 0.1020 = Kilograms Force
Pounds Force x 0.00448 = Kilonewtons
Kilonewtons x 224.8 = Pounds Force
Tonnes Force x 2204.6 = Pounds Force
Pounds Force x 0.00045359 = Tonnes Force

TEMPERATURE

Celsius = .55556 x (Fahrenheit - 32)
Fahrenheit = 1.8 x Celsius + 32



**SAMSON HIGH PERFORMANCE
SYNTHETIC ROPES WILL LOWER
OPERATING COSTS IN MOORING
AND TUG APPLICATIONS.**



SAMSON

1-800-227-7673 www.samsonrope.com



samson

2090 Thornton Street
Ferndale, WA 98248
U.S.A.

Phone: (800) 227-7673 or (360) 384-4669
Fax: (360) 384-0572
www.samsonrope.com

REGISTERED TRADEMARK NOTICES:

AmSteel[®], and 2-IN-1[®] are registered trademarks of Samson Rope Technologies.

Spectra[®] is a registered trademark of Honeywell Corporation.

Dyneema[®] is a registered trademark of DSM High Performance Fibers BV.

Vectran[®] is a registered trademark of Hoechst Celanese Corporation.

Technora[®] is a registered trademark of Teijin, Ltd.

